

# CROSS RC

USER'S MANUAL



RADIO CONTROL SCALE ELECTRIC 4WD  
WWW.CROSS-RC.COM

SCALE 4X4  
OFF-ROAD

PG4

TR

1/10 FULL-SIZE PICKUPS KIT VERSION

## CAUTIONS



To prevent serious personal injury and/or property damage, operate all remotely controlled models in a responsible manner as outlined herein.

### ● Safety Precautions

- 1.1 Choose a right place to operate your RC model.
- 1.2 Do not operate your RC model on the street or highway. It can cause a serious damage or a serious accident.
- 1.3 Never operate your RC model near people or animals.
- 1.4 Do not operate RC model in public places like hospital and residential areas.
- 1.5 Never operate RC model indoors. There is a higher possibility of fire or damage.
- 1.6 Keep the parts out of reach of children, small parts can cause choking and vinyl bags can suffocate.
- 1.7 Do not use with children younger than 14 years.

### ● Inspect your RC model before operation

- 2.1 Make sure that all screws and nuts are properly tightened. It is also a good idea to use removable thread lock wherever metal screws go into metal, especially for engine mounts and the engine pilot shaft.
- 2.2 Always use fresh batteries for your transmitter and for your receiver to avoid losing control of the model.
- 2.3 Always test the brakes and throttle before starting your engine to avoid losing control of the model.
- 2.4 Always turn on the transmitter first, and then turn on the receiver.

### ● After operation of your RC model

- 3.1 Turn off receiver first, then turn off transmitter, this will prevent runaways.
- 3.2 Be careful when handling batteries, they will be hot after running.
- 3.3 Replace any batteries that have been dented or have frayed wires, short circuits can cause fire.

## TOOLS

(Not included)

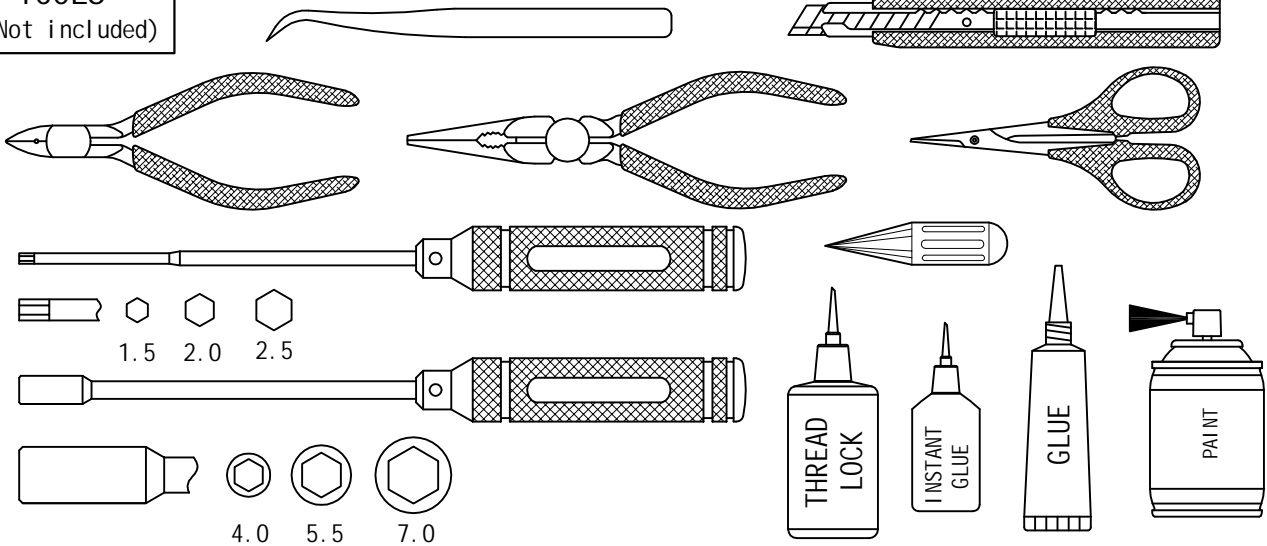

## Electronic equipment

(Not included)

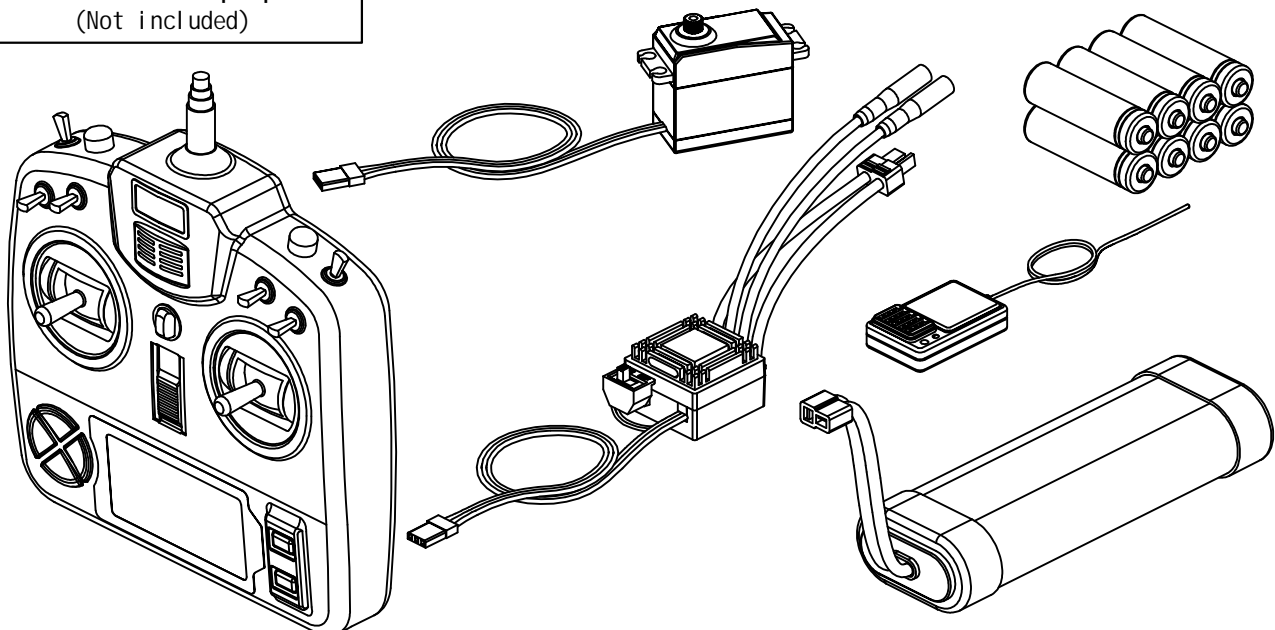

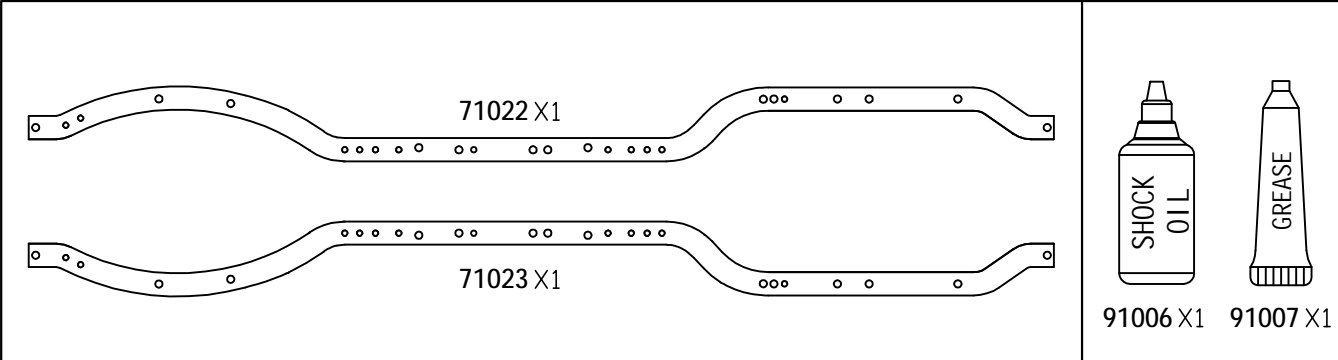

BAG(A)

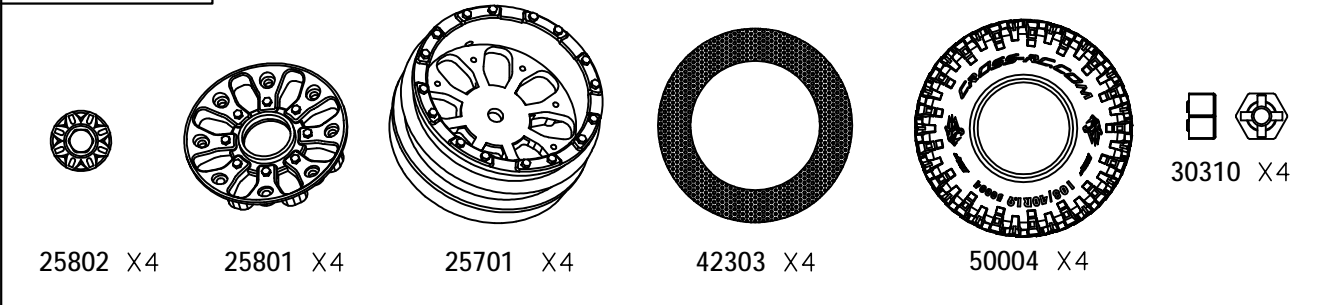

BAG(FA)

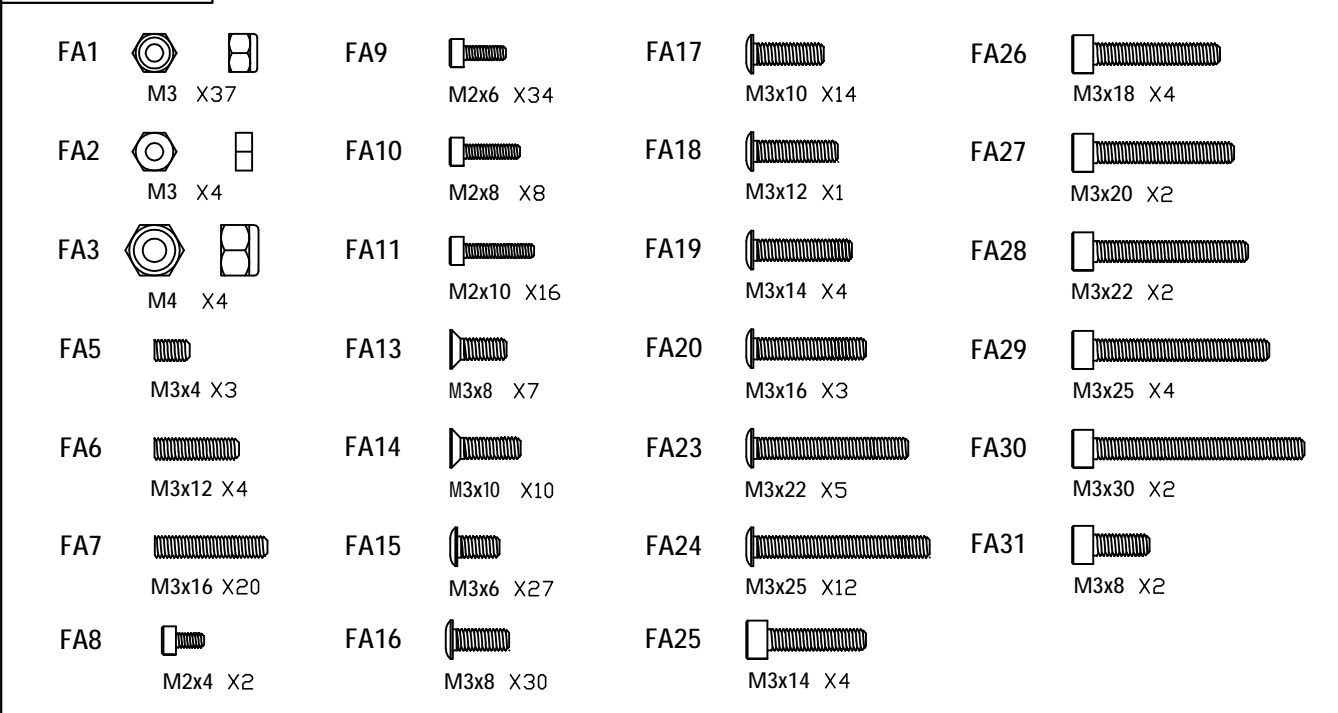

BAG(FB)

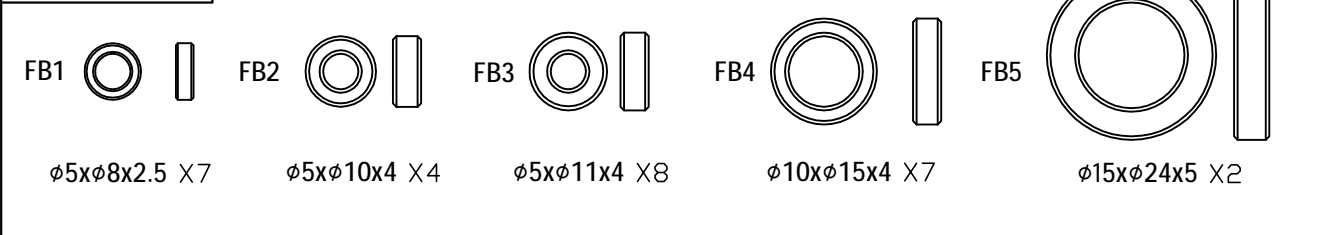

BAG(FC)

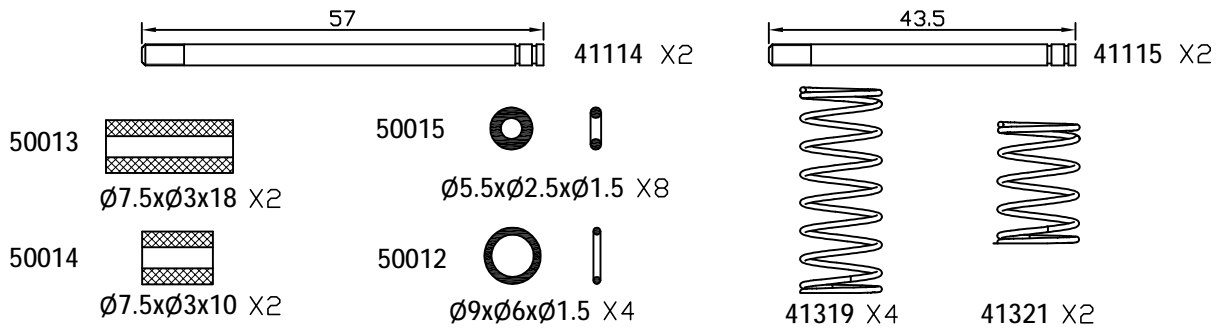

BAG(FD)

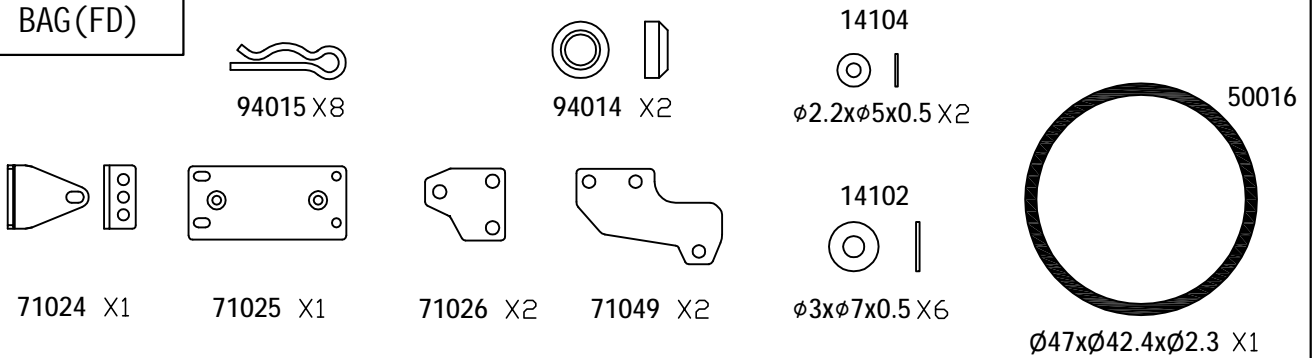

BAG(FF)

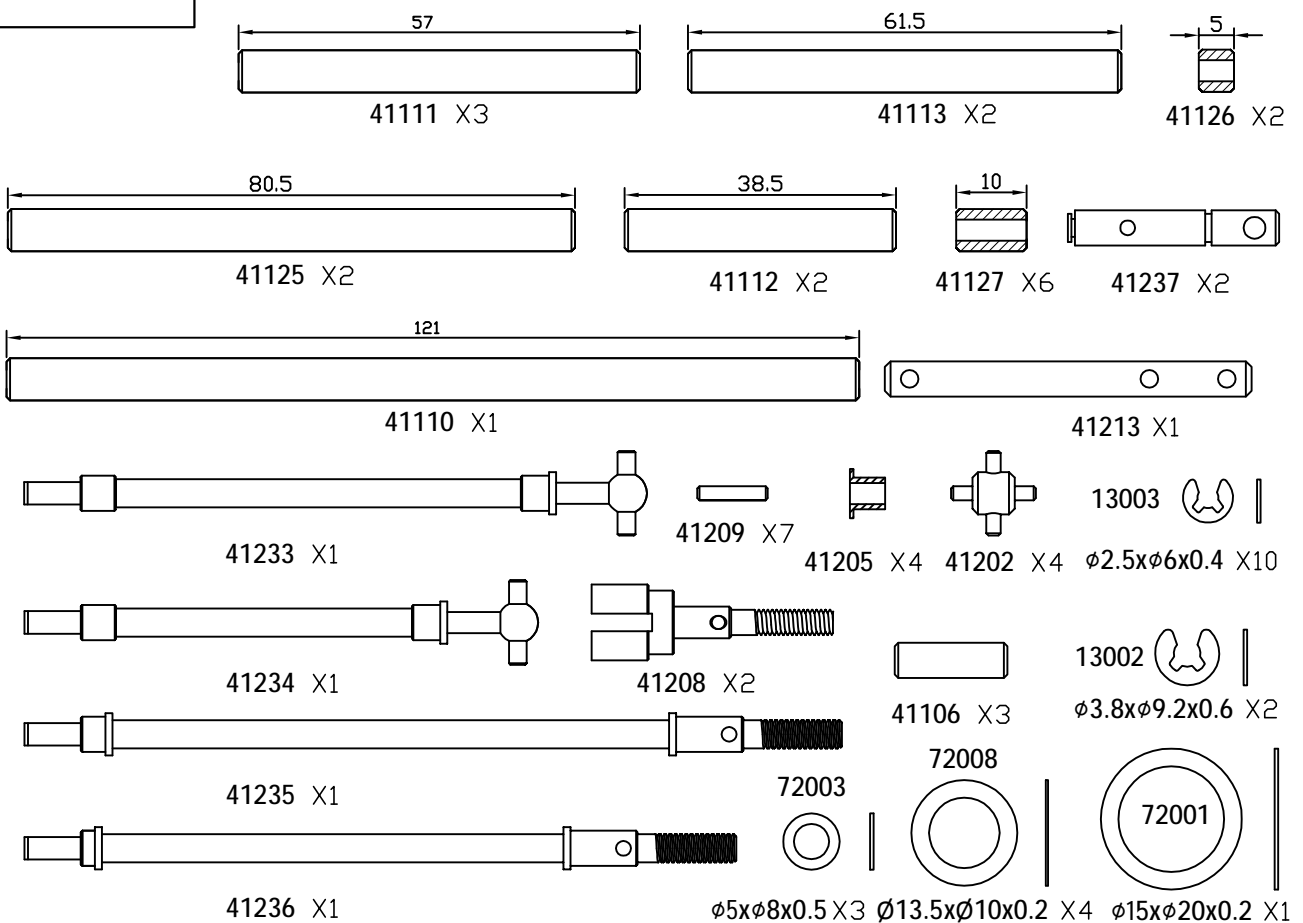

BAG(FE)

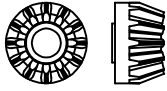

30202(12T) X2

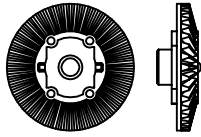

30201(36T) X2

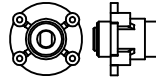

30205 X2

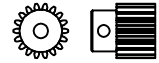

41304(18T) X1

BAG(FG)



23403 X1



23404 X1



25902 X2

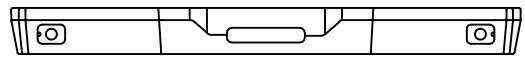

22606 X1

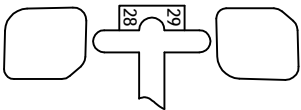

23028 X1

23029 X1

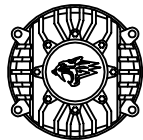

23037 X2



22607 X1

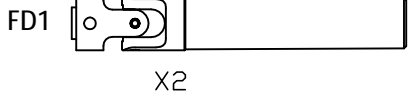

X2

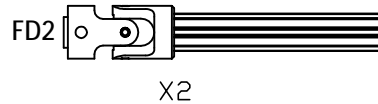

X2

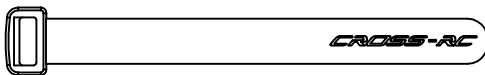

91004 X2

Ø10xØ5x2



42306 X1



20301 X3

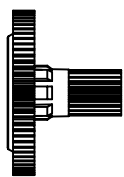

20302 X1

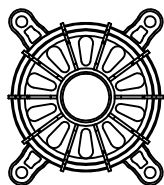

20306 X1

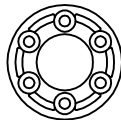

20401 X1

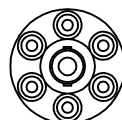

20402 X1

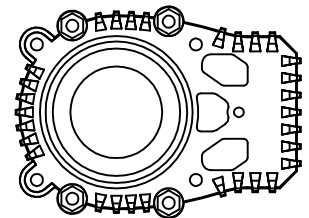

20405 X1



20403 X1



20404 X1

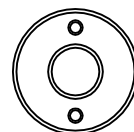

20407 X1

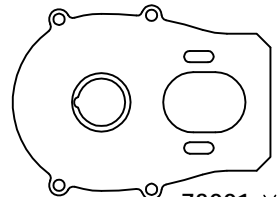

73001 X1

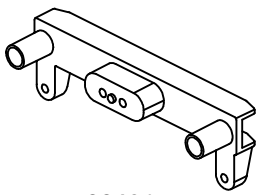

22401 X1

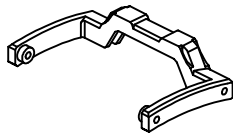

22402 X1

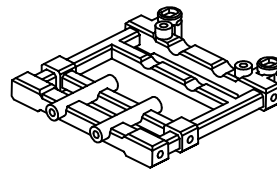

22403 X1

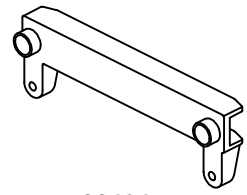

22404 X1

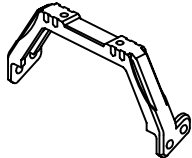

22405 X1

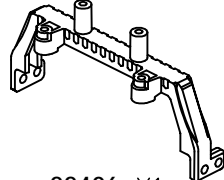

22406 X1

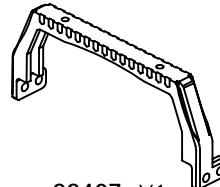

22407 X1

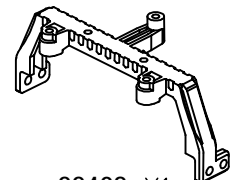

22408 X1

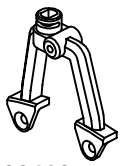

22409 X1

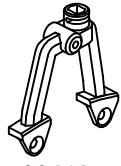

22410 X1

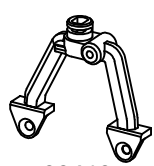

22412 X1

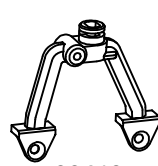

22413 X1

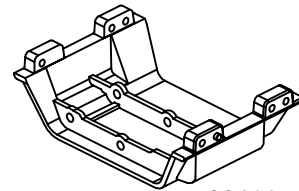

22411 X1

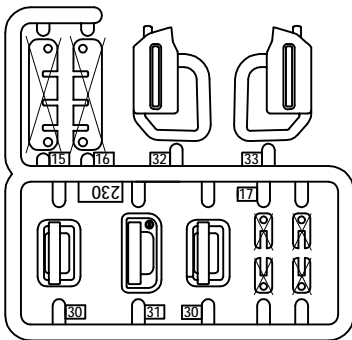

23030 X2  
23031 X1  
23032 X1  
23033 X1

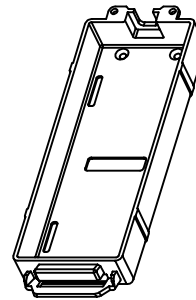

22901 X1

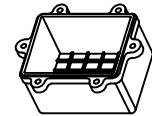

22902 X1

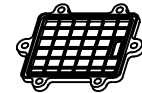

22903 X1



23101 X2



23102 X2



23103 X4

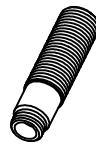

23104 X2



23105 X2



23106 X4



23107 X4



23108 X4



23109 X4



23110 X4



23111 X2



23112 X2

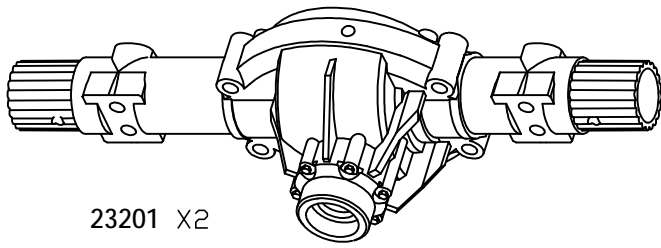

23201 X2

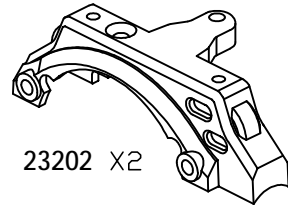

23202 X2

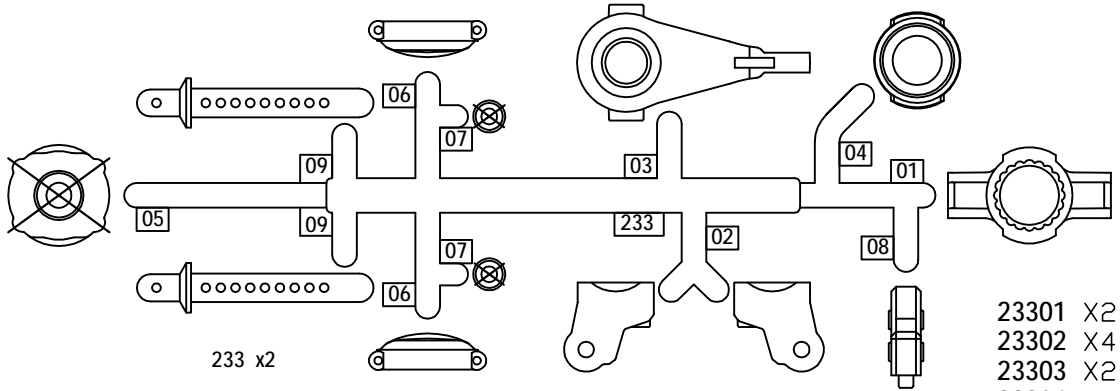

233 x2

- 23301 X2
- 23302 X4
- 23303 X2
- 23304 X2
- 23306 X4
- 23308 X2
- 23309 X4

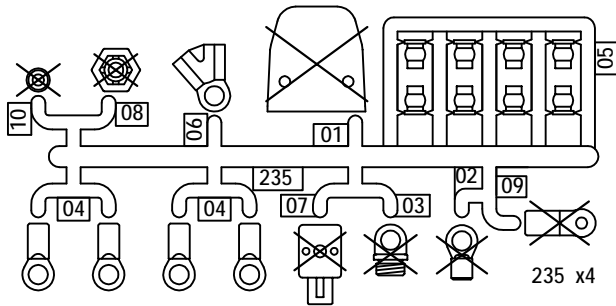

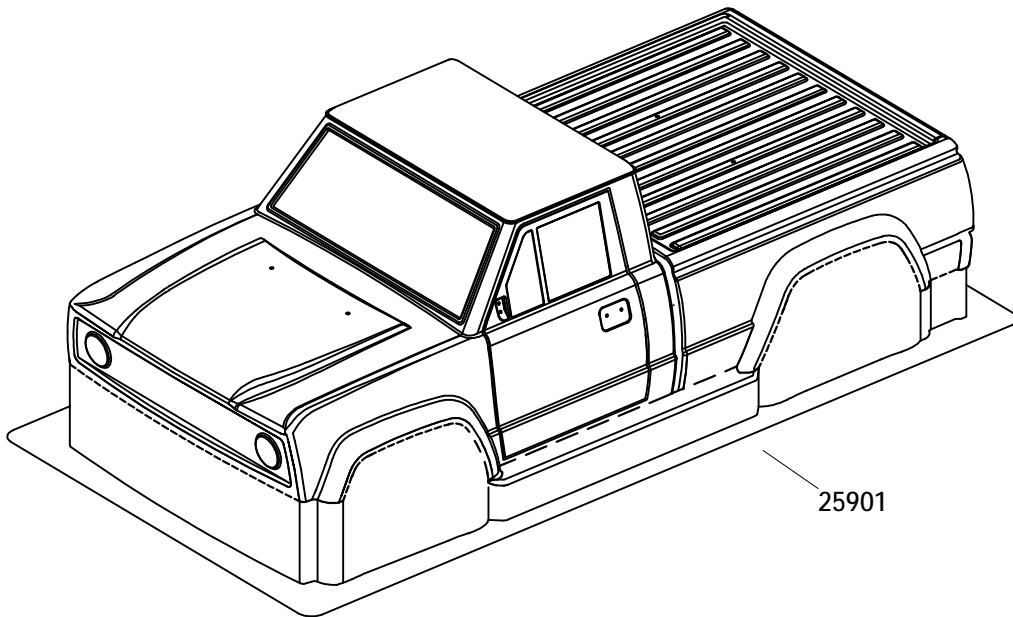

235 x4

- 23504 X12
- 23505 X26
- 23506 X2



25901

FA11   
M2x10 X8

13003   
ø2.5xø6x0.4 X2

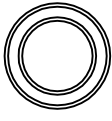
FB4   
ø10xø15x4 X4

  
72008 X4

**1**

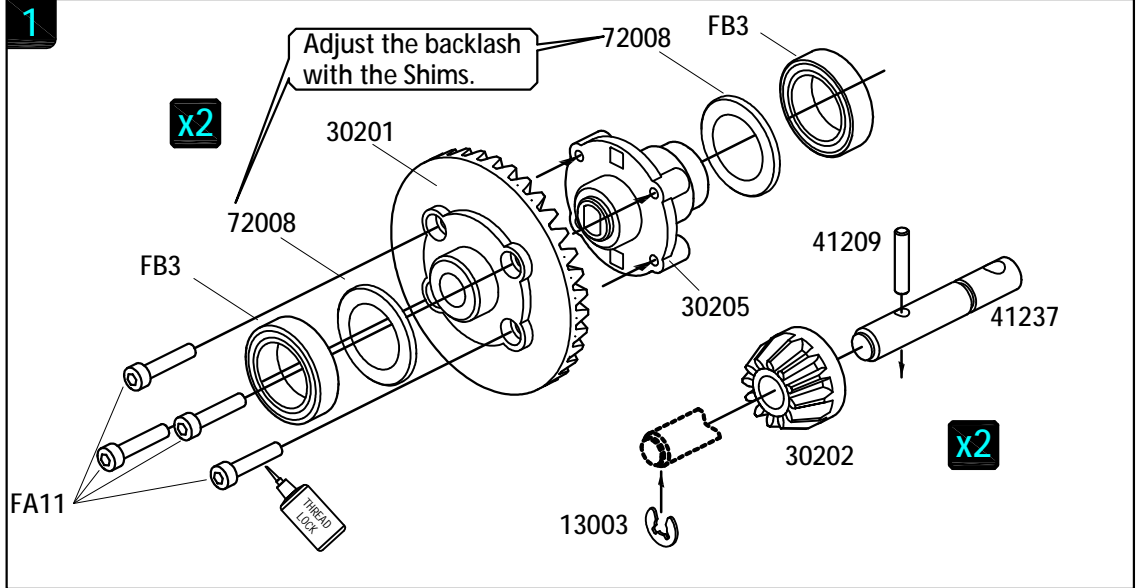



FA10   
M2x8 X8

FA11   
M2x10 X8

FB3   
ø5xø11x4 X4

FA5   
M3x4 X2

13002   
ø3.8xø9.2x0.6 X2

72003   
ø5xø8x0.5 X2

**2**

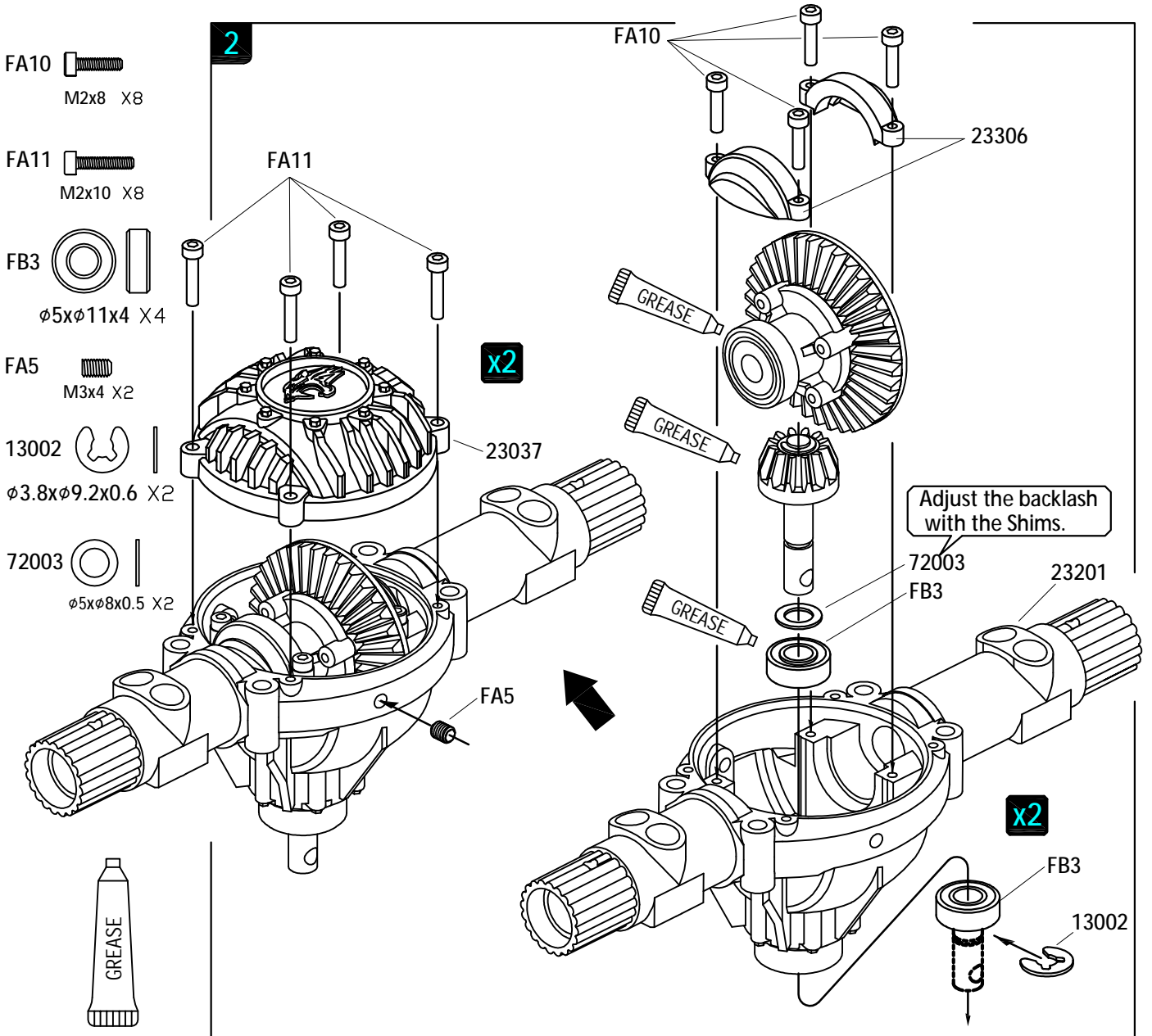





4

41235 X1

116

41236 X1

101

FB3  
φ5xφ11x4 X2



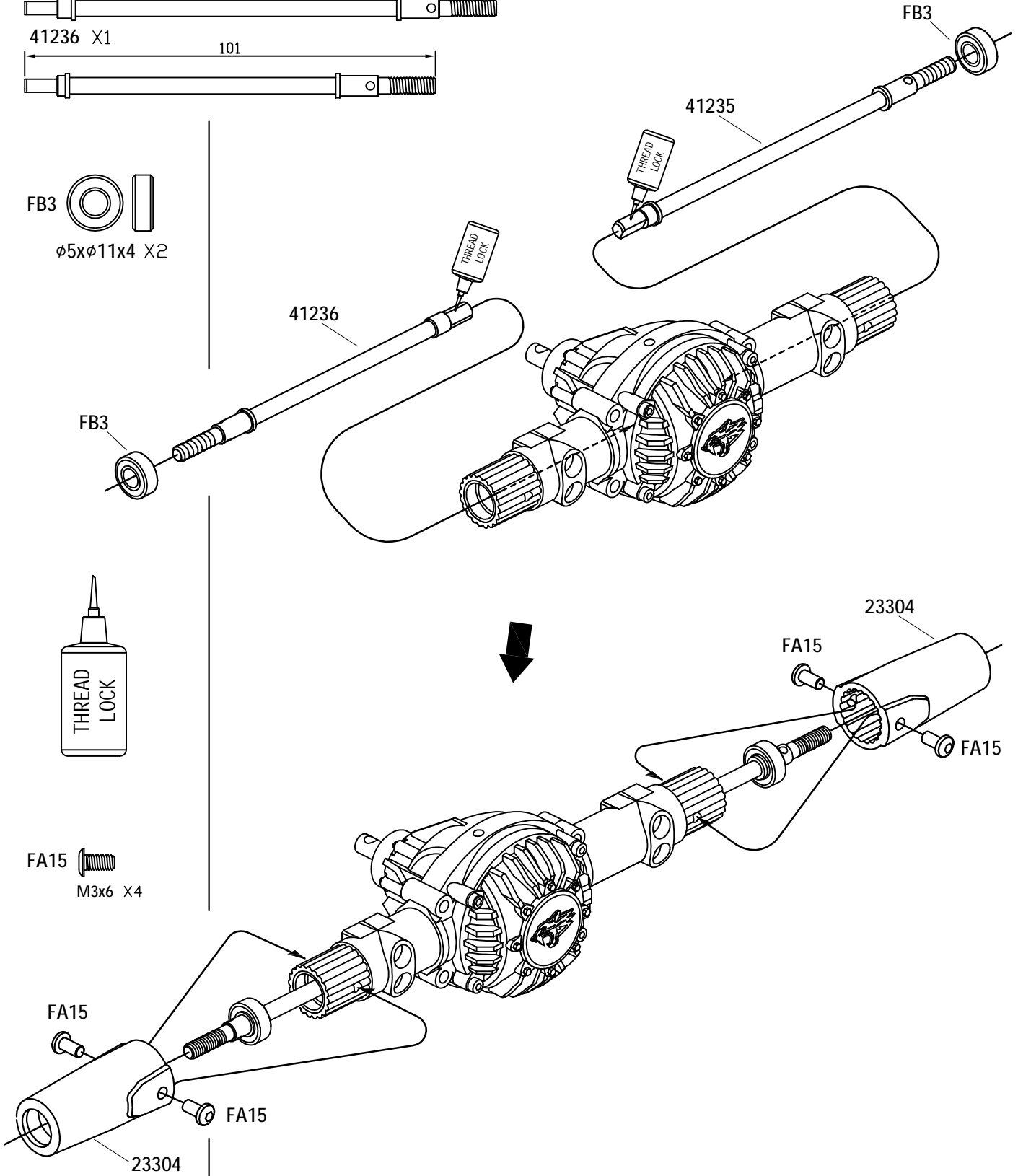

FA15  
M3x6 X4





5

FA1   
M3 X6

FA14   
M3x10 X1

FA23   
M3x22 X2

FA26   
M3x18 X2

FA29   
M3x25 X2

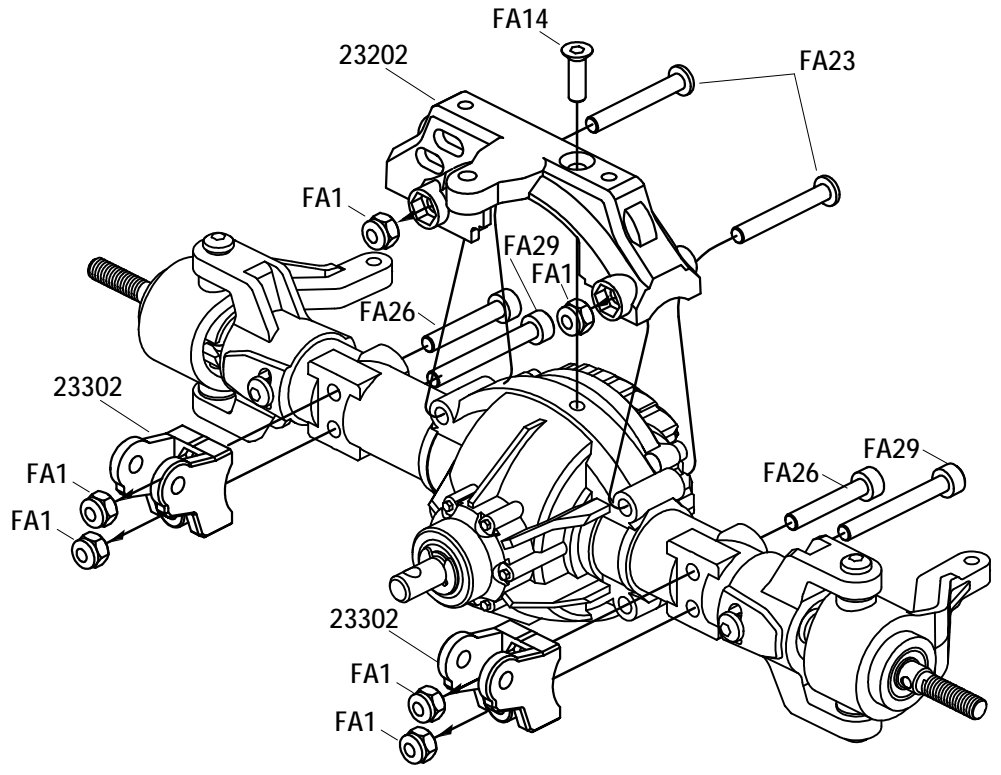



6

FA1   
M3 X6

FA14   
M3x10 X1

FA23   
M3x22 X2

FA26   
M3x18 X2

FA29   
M3x25 X2

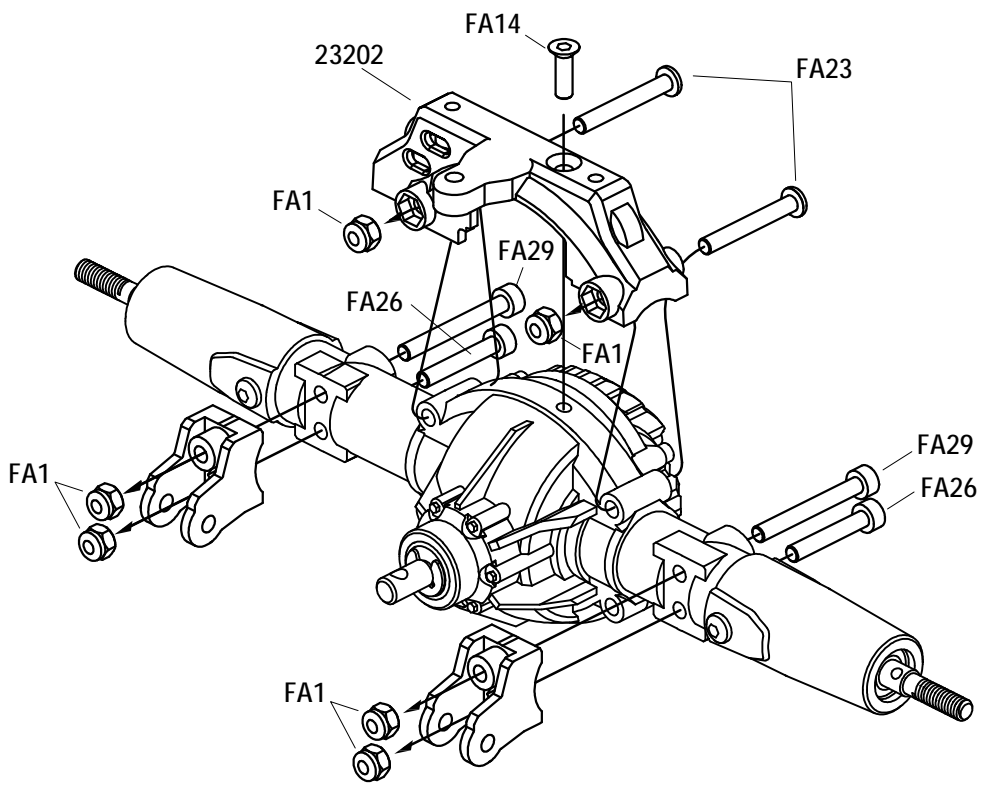

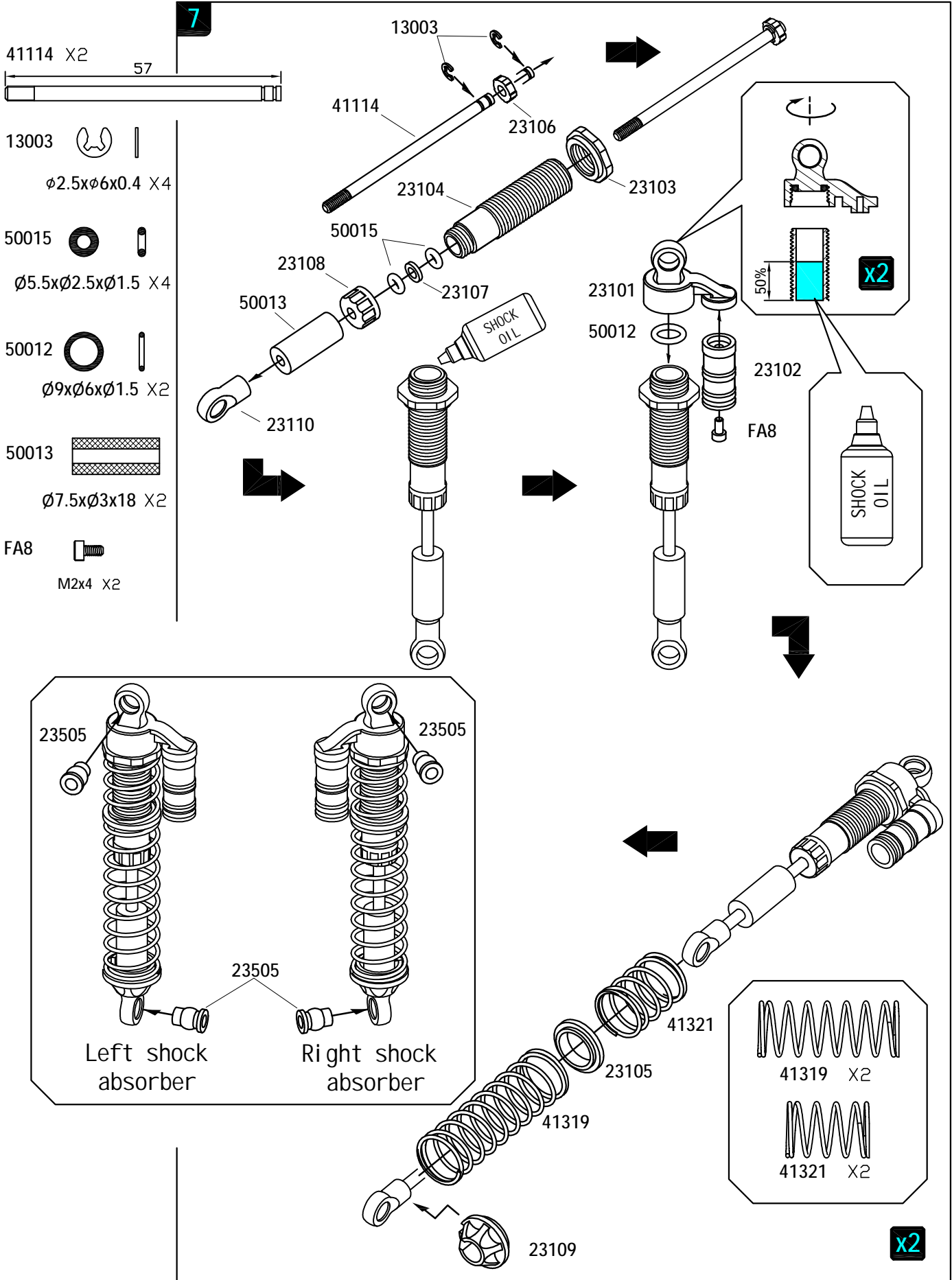

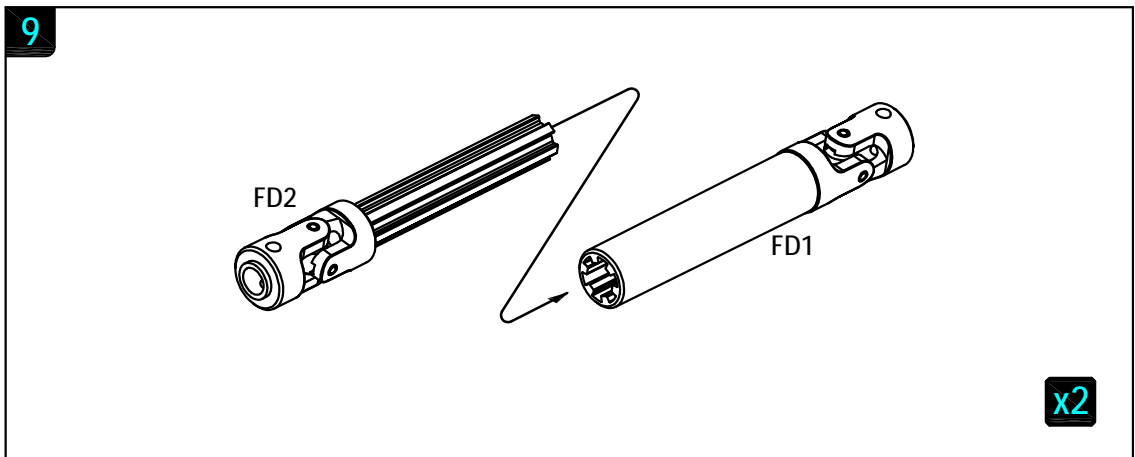
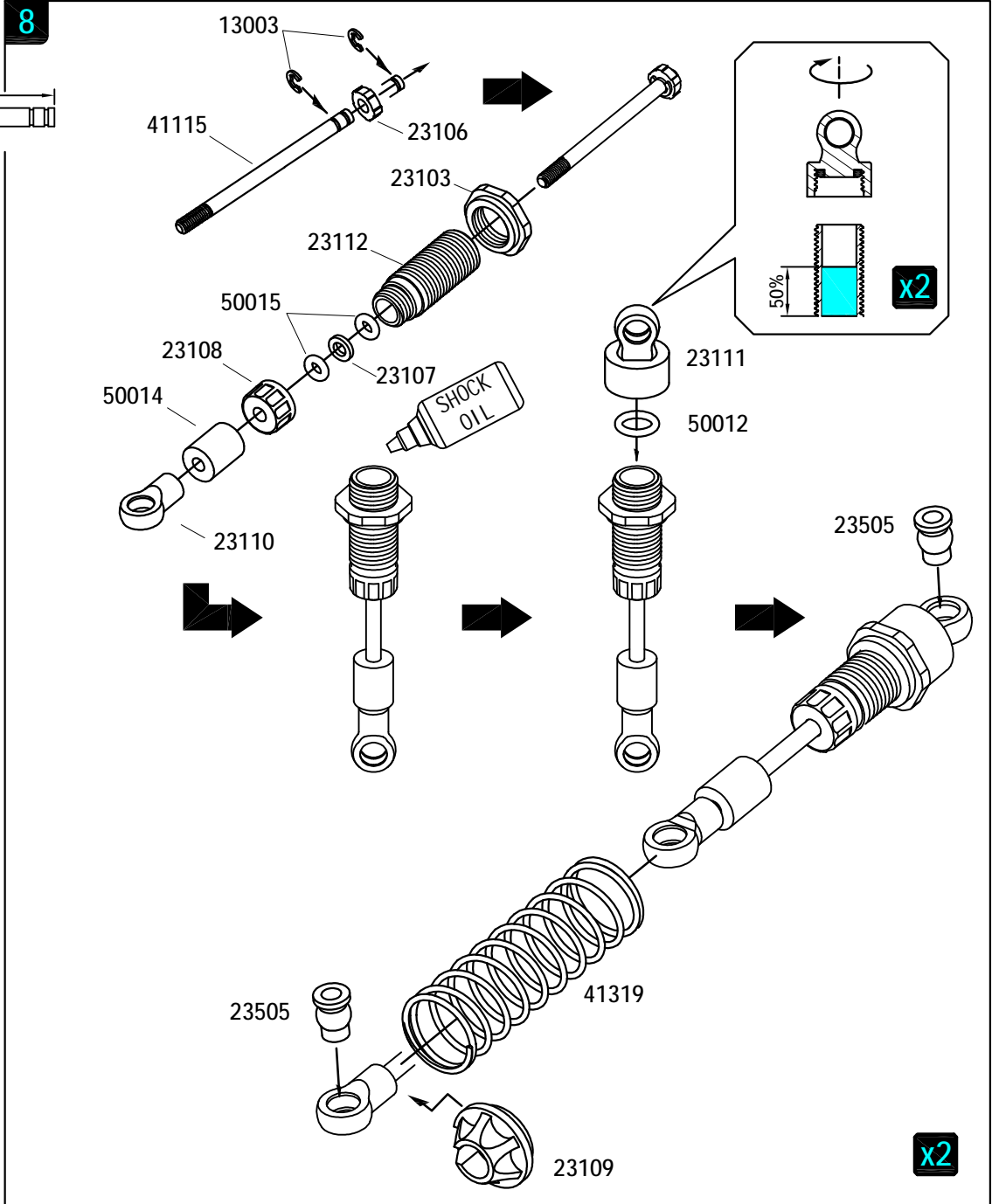

10

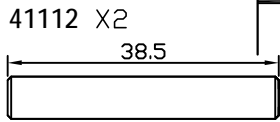

FA7  
M3x16 X4

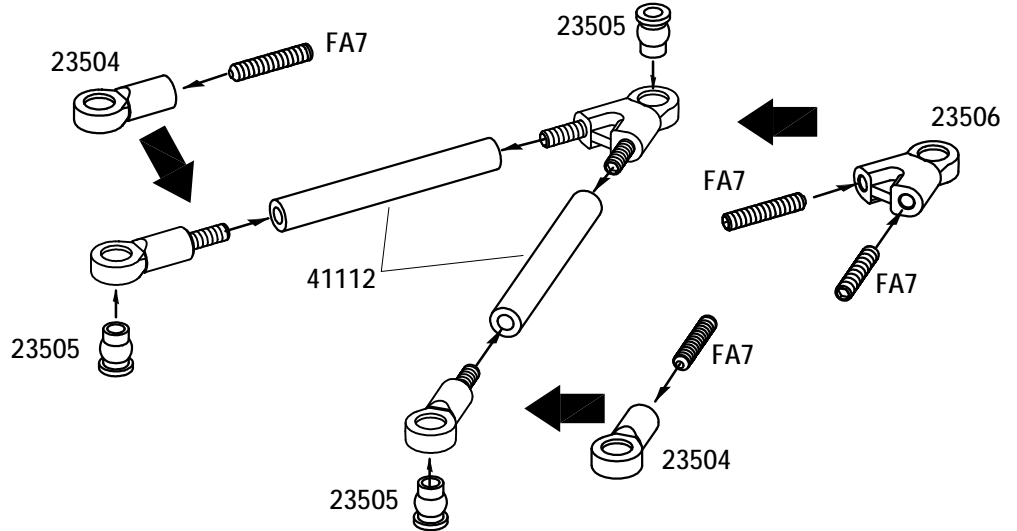

11

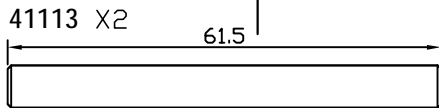

FA7  
M3x16 X4

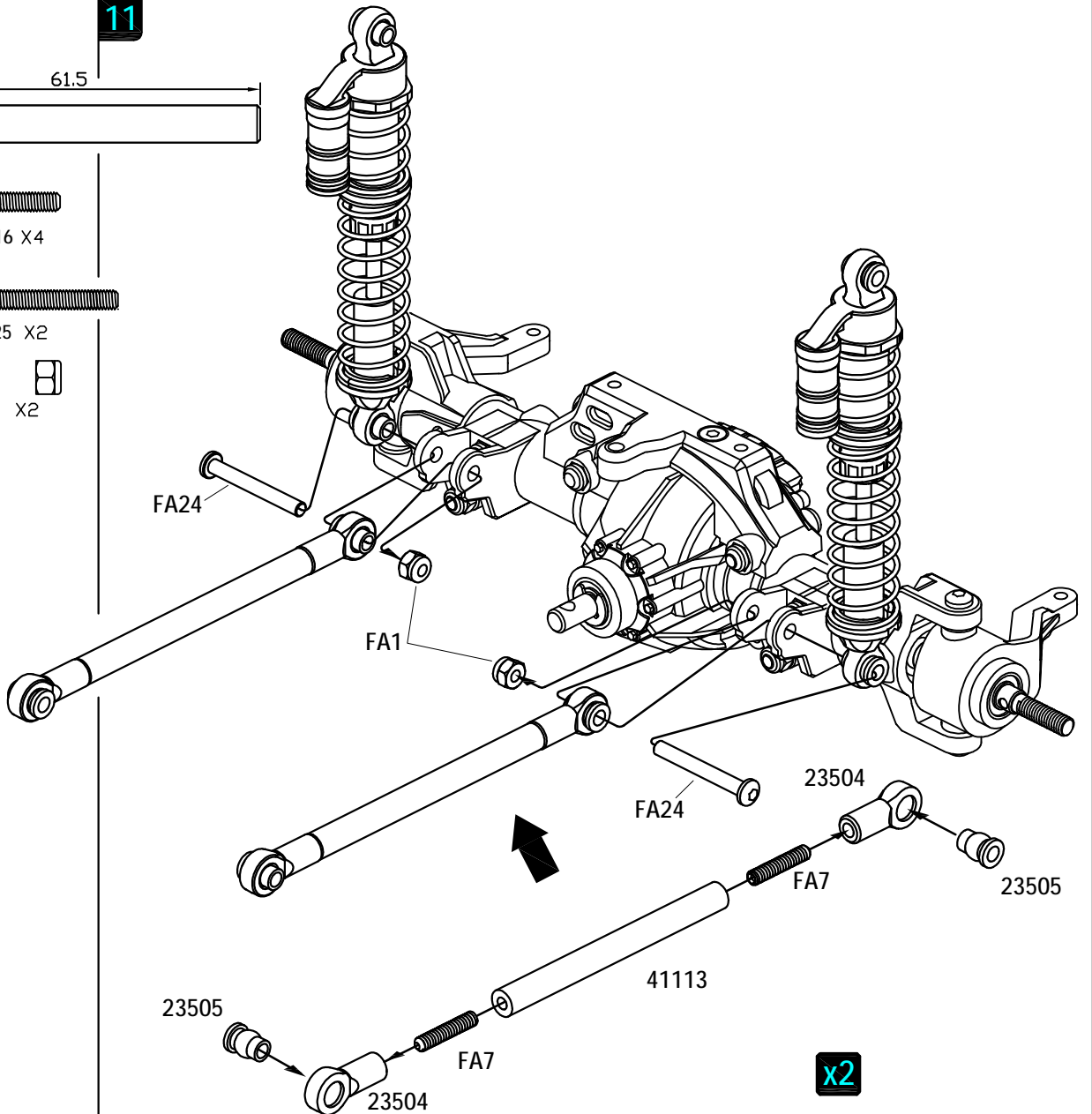

FA24  
M3x25 X2

FA1  
M3 X2





x2

12

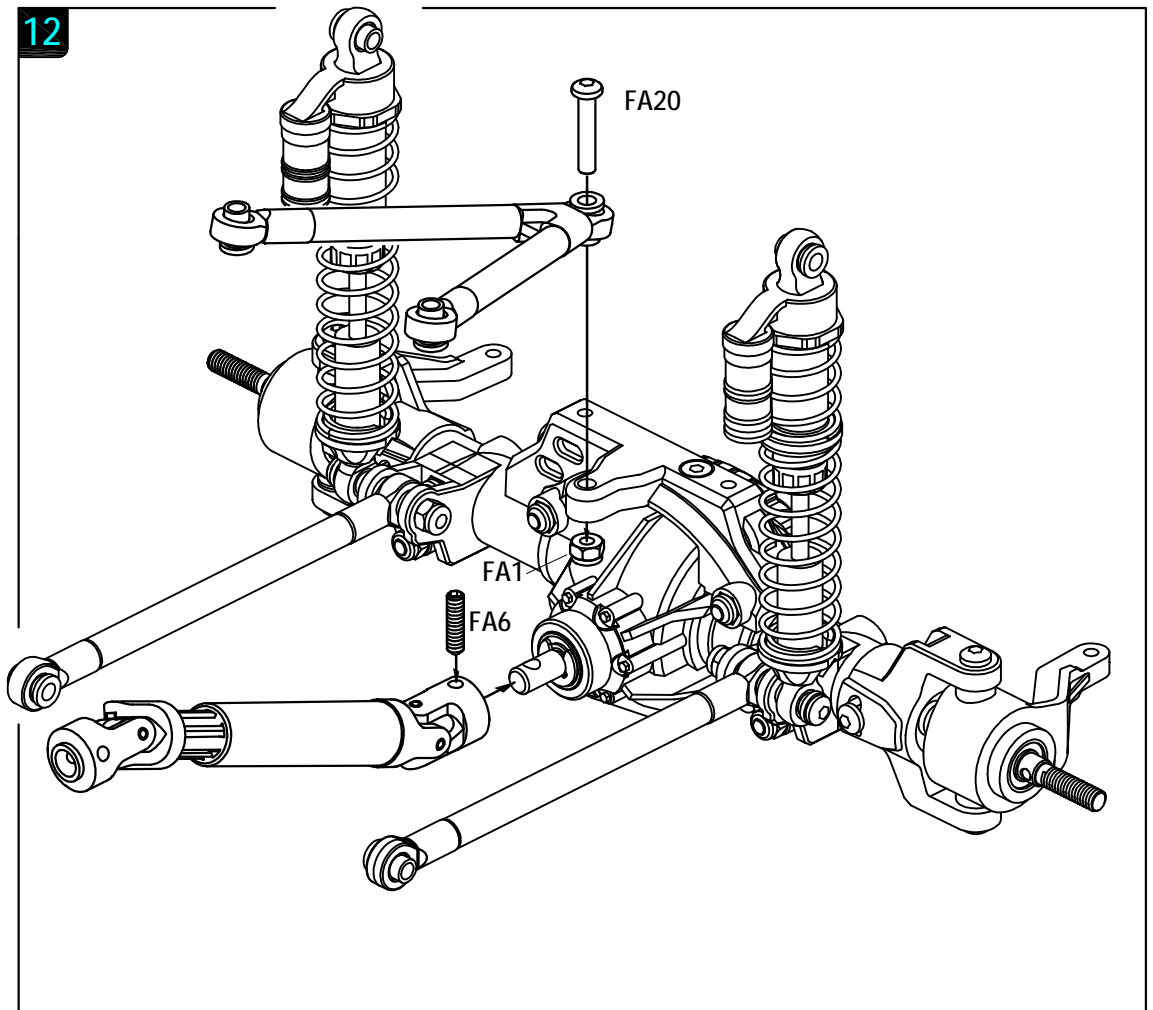
- FA1  M3 X1
- FA6  M3x12 X1
- FA20  M3x16 X1



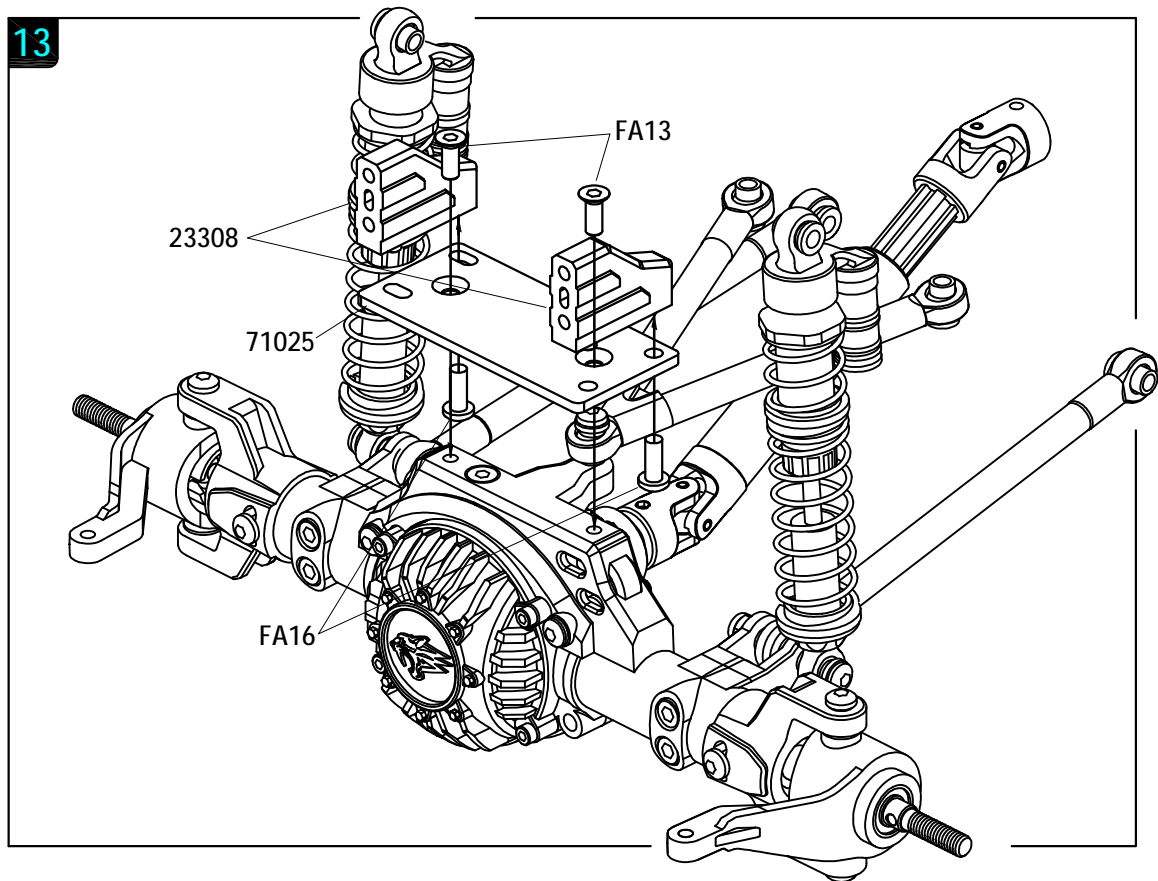

13

- FA13  M3x8 X2
- FA16  M3x8 X2
- 71025  X1



14

FA17   
M3x10 X4

14102   
φ3xφ7x0.5 X4

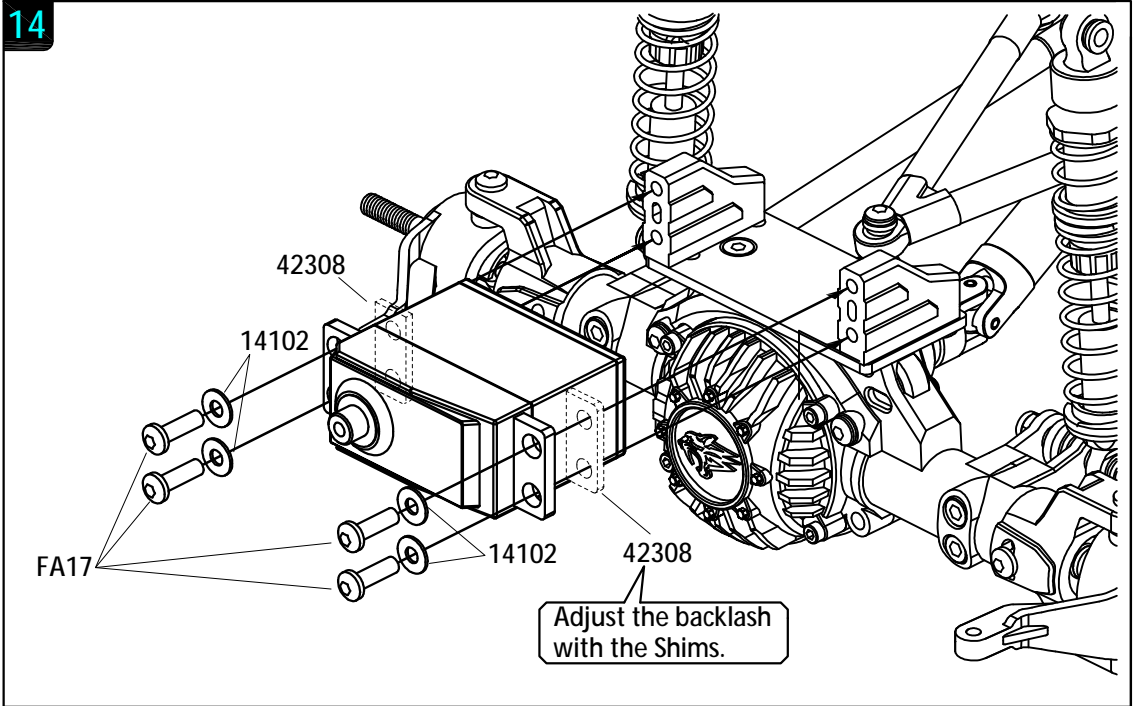

15

FA7   
M3x16 X4

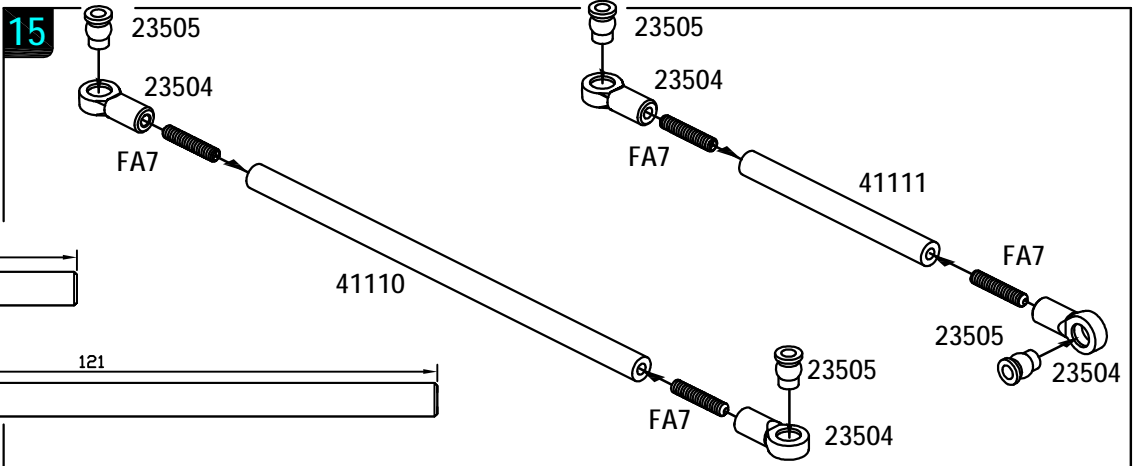
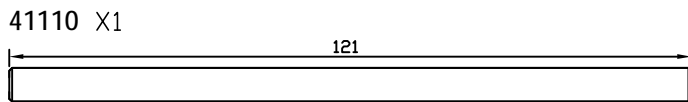
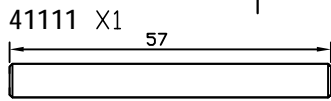

16

FA15   
M3x6 X1

FA18   
M3x12 X1

FA20   
M3x16 X1

FA23   
M3x22 X1

FA1   
M3 X1

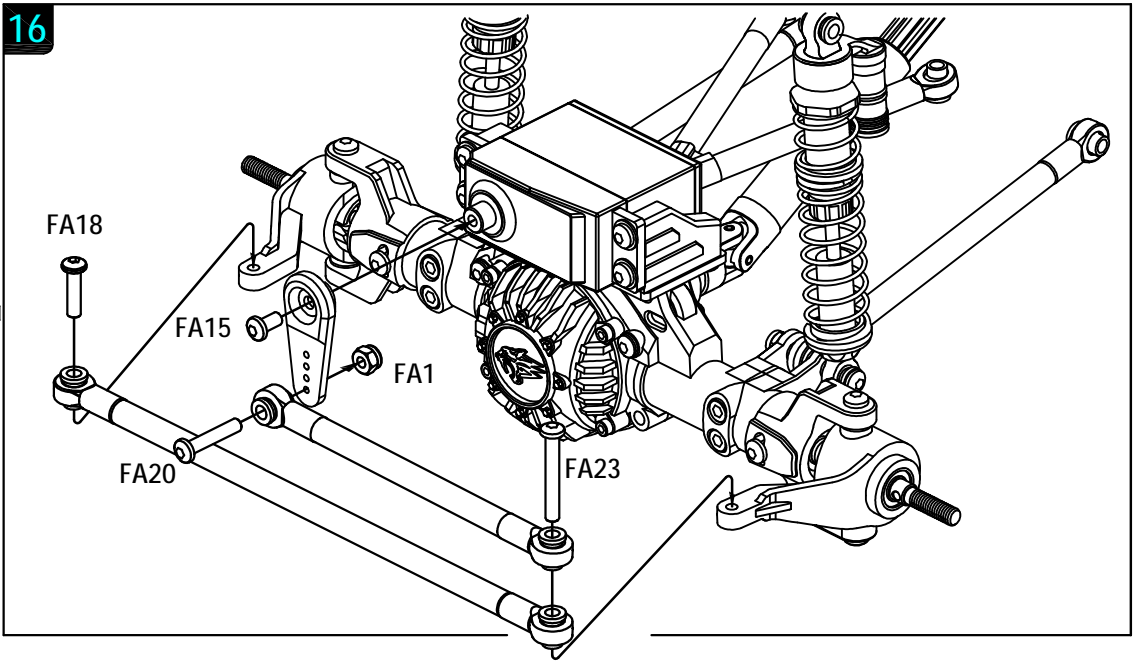



17

FA7  
M3x16 X4

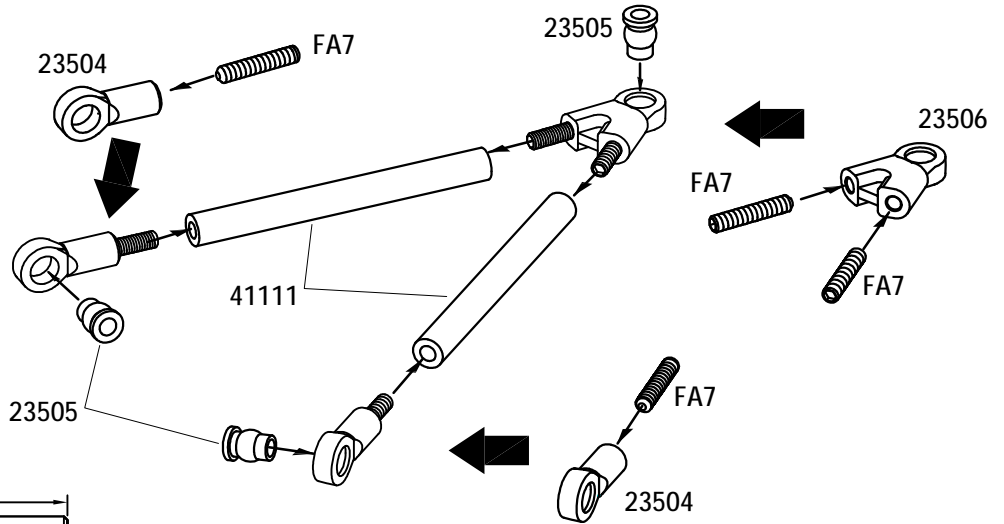

18

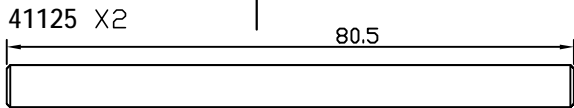

FA6  
M3x12 X1

FA7  
M3x16 X4







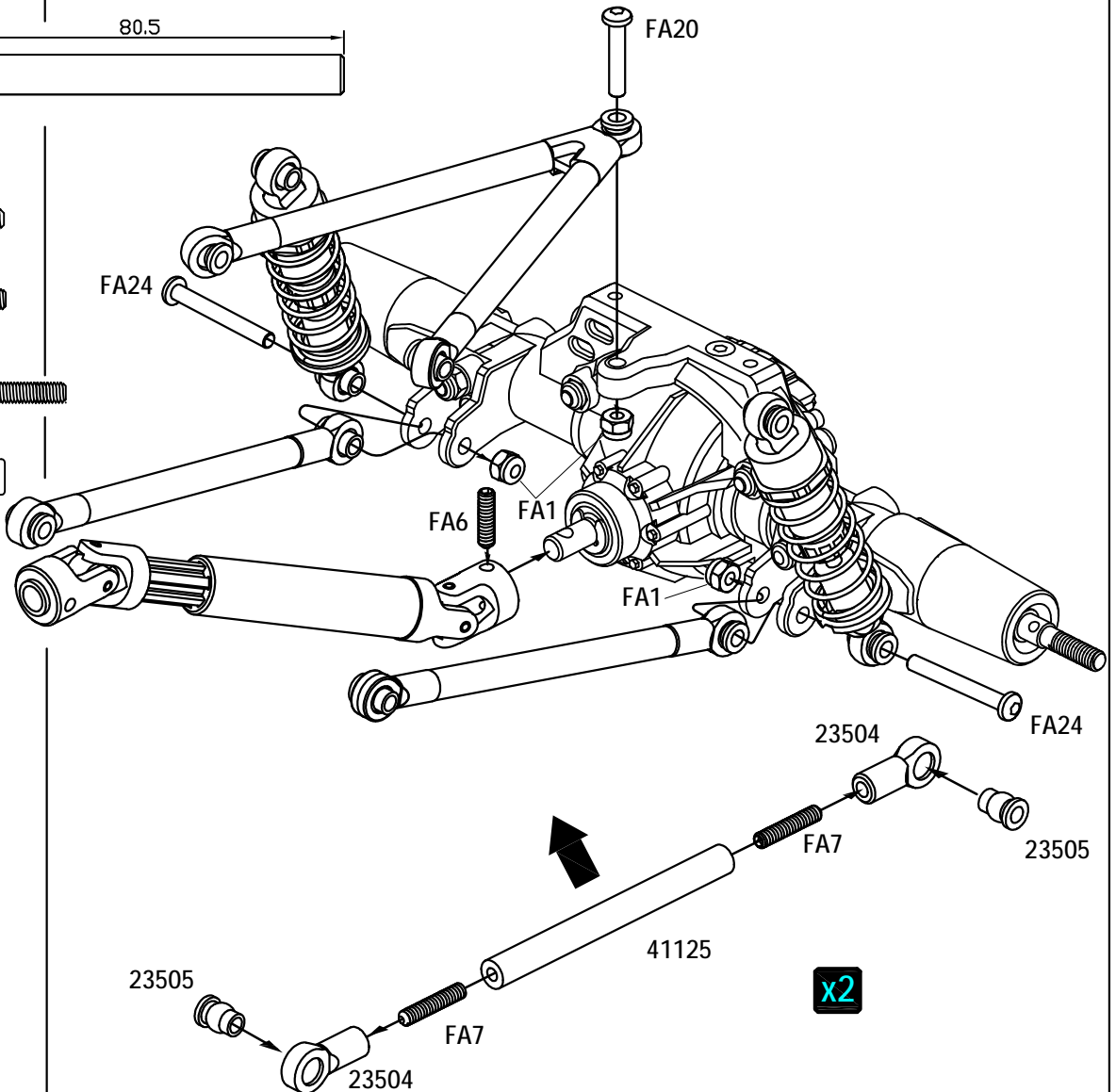

FA20  
M3x16 X1

FA24  
M3x25 X2

FA1  
M3 X3







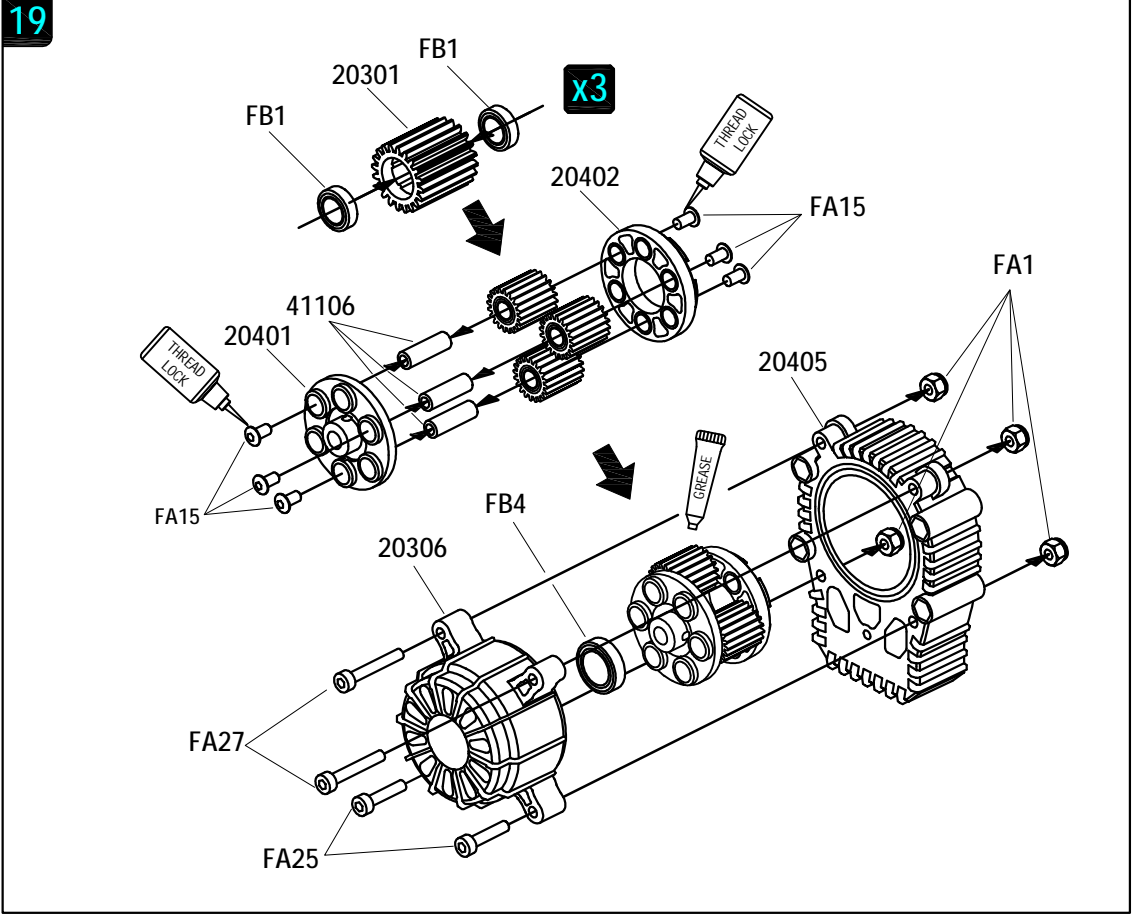

19

- FA1  M3 X4
- FA15  M3x6 X6
- FA25  M3x14 X2
- FA27  M3x20 X2
- FB1   $\phi 5 \times \phi 8 \times 2.5 \times 6$
- FB4   $\phi 10 \times \phi 15 \times 4 \times 1$
-  THREAD LOCK
-  GREASE



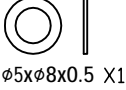

20

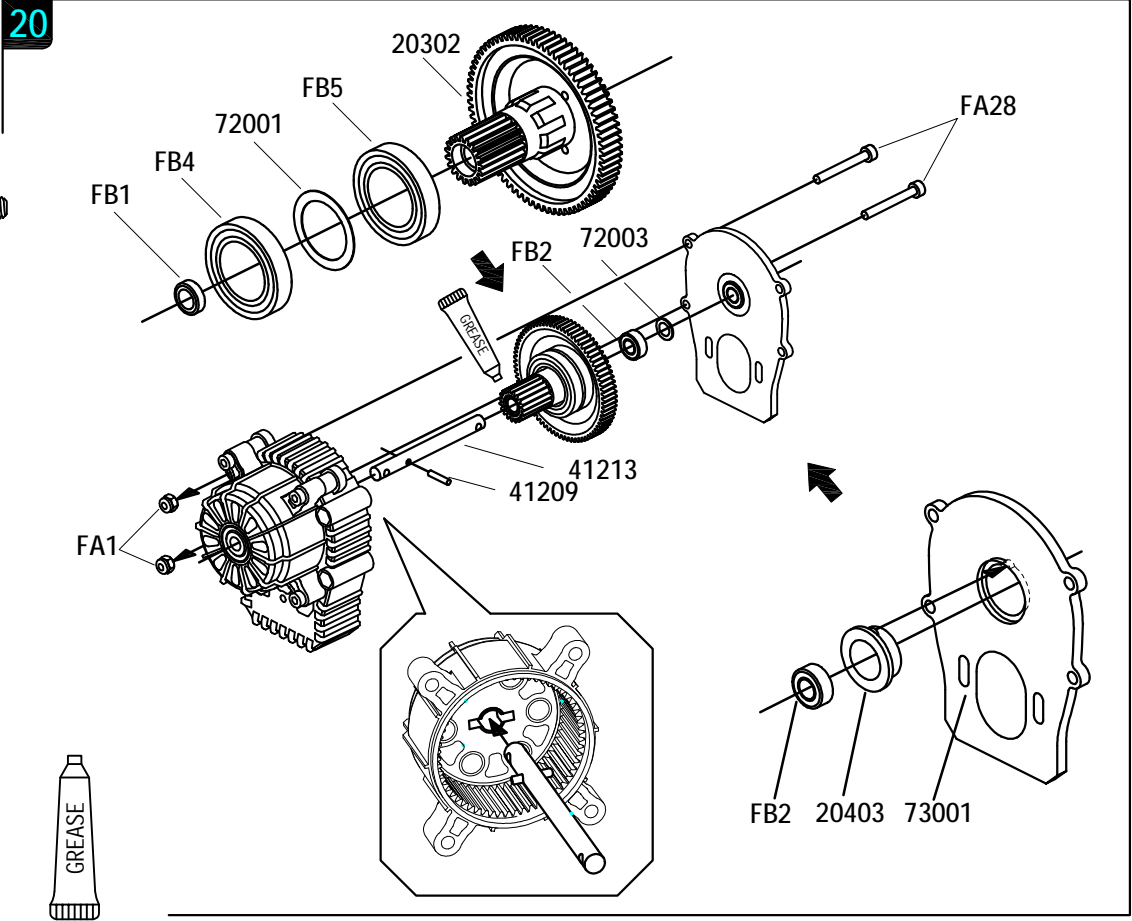
- FA1  M3 X2
- FA28  M3x22 X2
- FB1   $\phi 5 \times \phi 8 \times 2.5 \times 1$
- FB2   $\phi 5 \times \phi 10 \times 4 \times 2$
- FB5   $\phi 15 \times \phi 24 \times 5 \times 2$
- 72003   $\phi 5 \times \phi 8 \times 0.5 \times 1$
- 72001   $\phi 15 \times \phi 20 \times 0.2 \times 1$
-  GREASE



21

FA5  M3x4 X1

FA25  M3x14 X2

14102   $\phi 3 \times \phi 7 \times 0.5$  X2

FA13  M3x8 X1

FA1  M3 X2

FA30  M3x30 X2

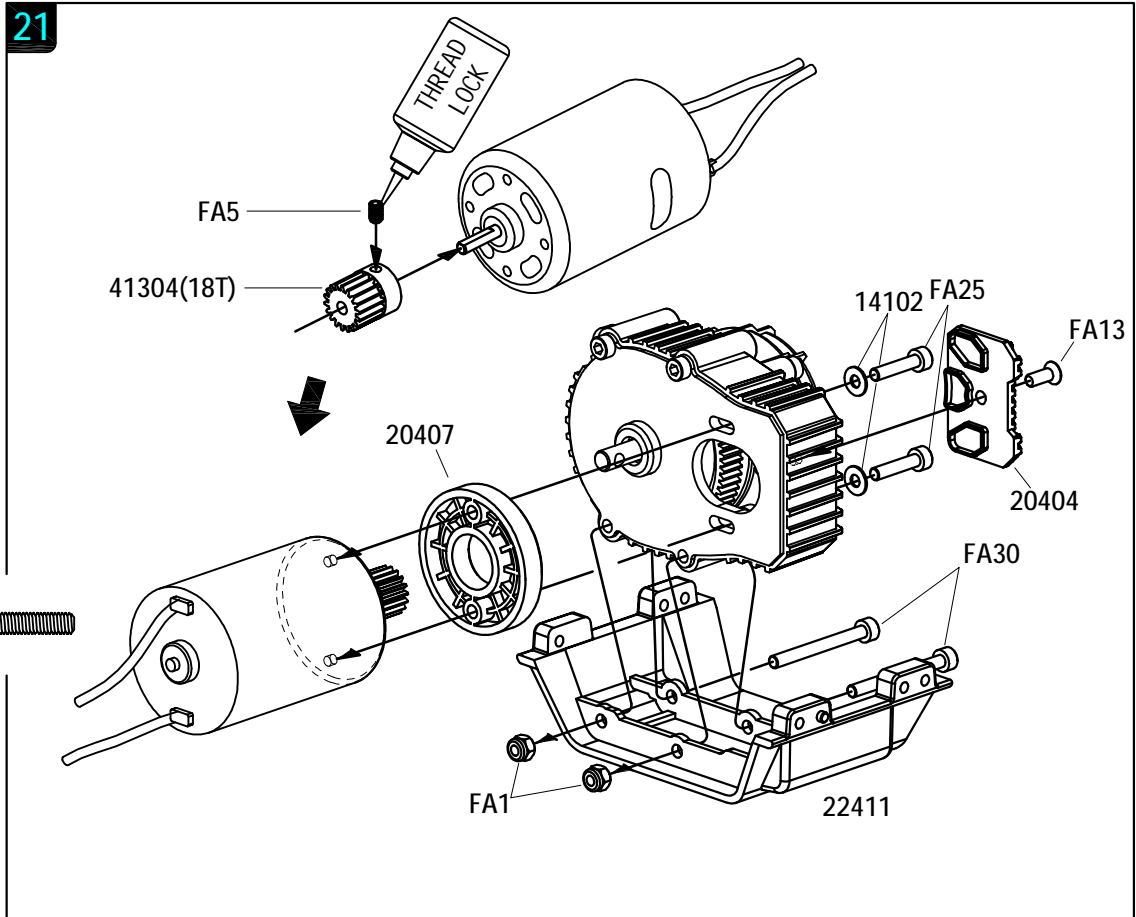



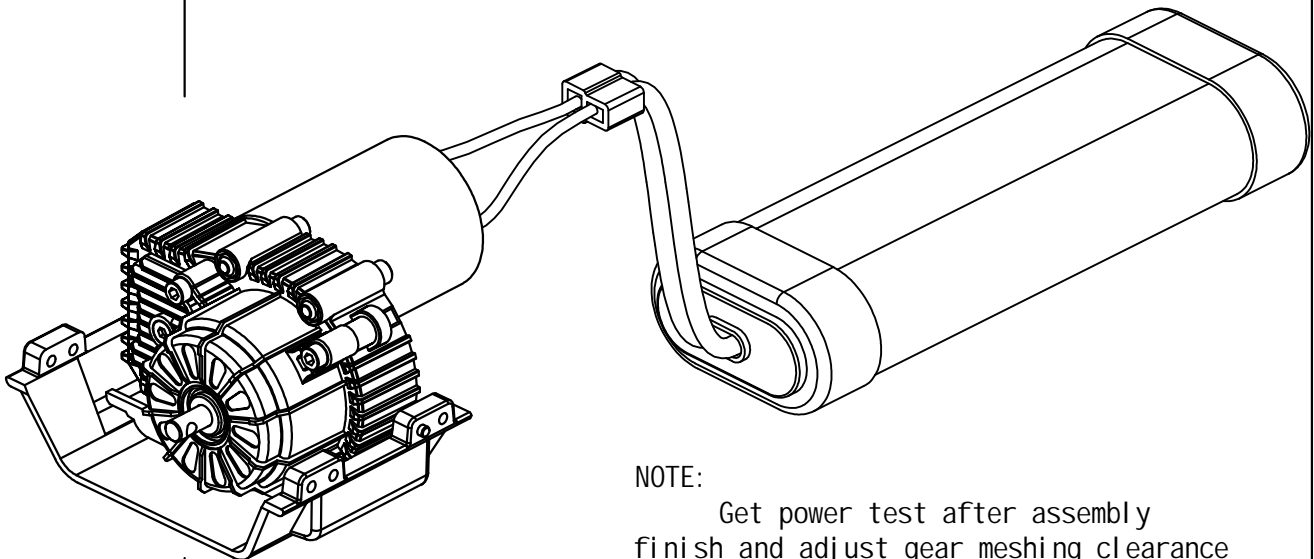

22





NOTE:

Get power test after assembly finish and adjust gear meshing clearance for make sure gear box running smooth without noise, then process to following assembly go on.

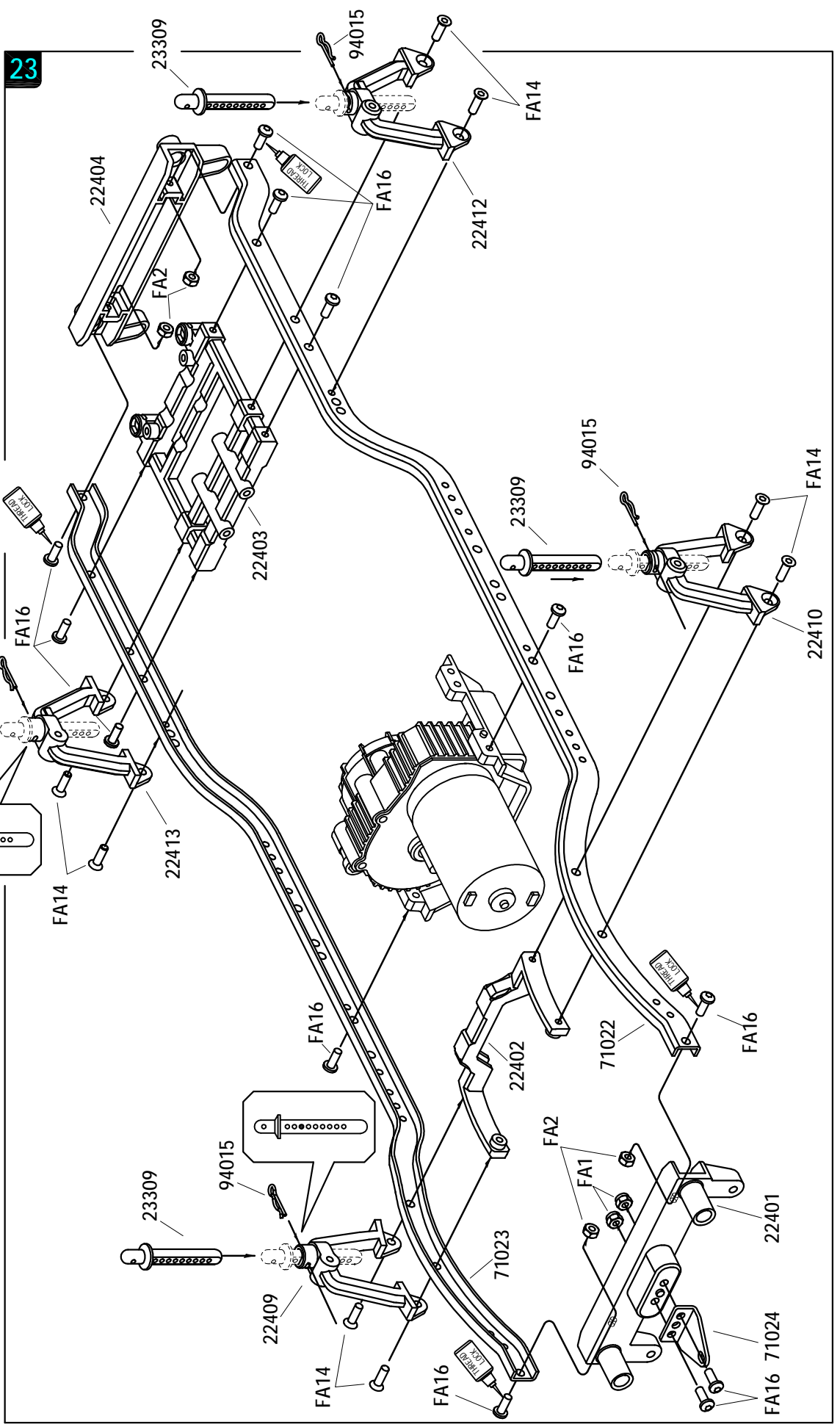
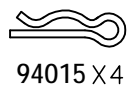
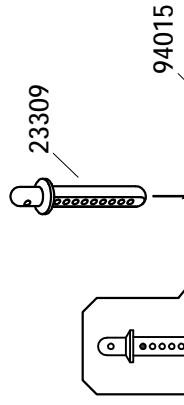
- FA16  M3x8 X12
- FA1   M3 X2
- FA2  M3 X4
- FA14  M3x10 X8



- FA15  M3x6 X10
- FA16  M3x8 X8
- FA17  M3x10 X4

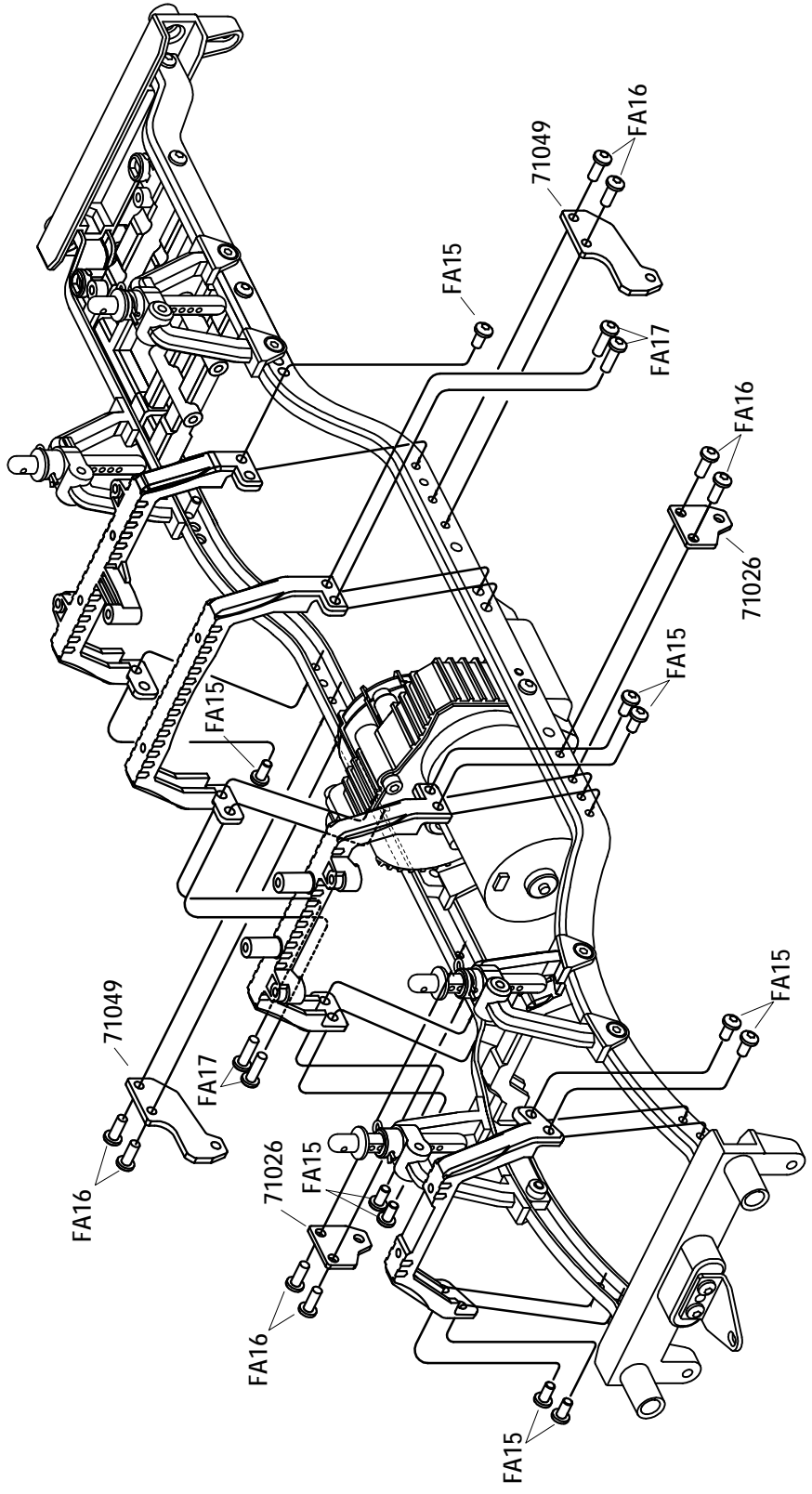

25

FA16  
M3x8 X2

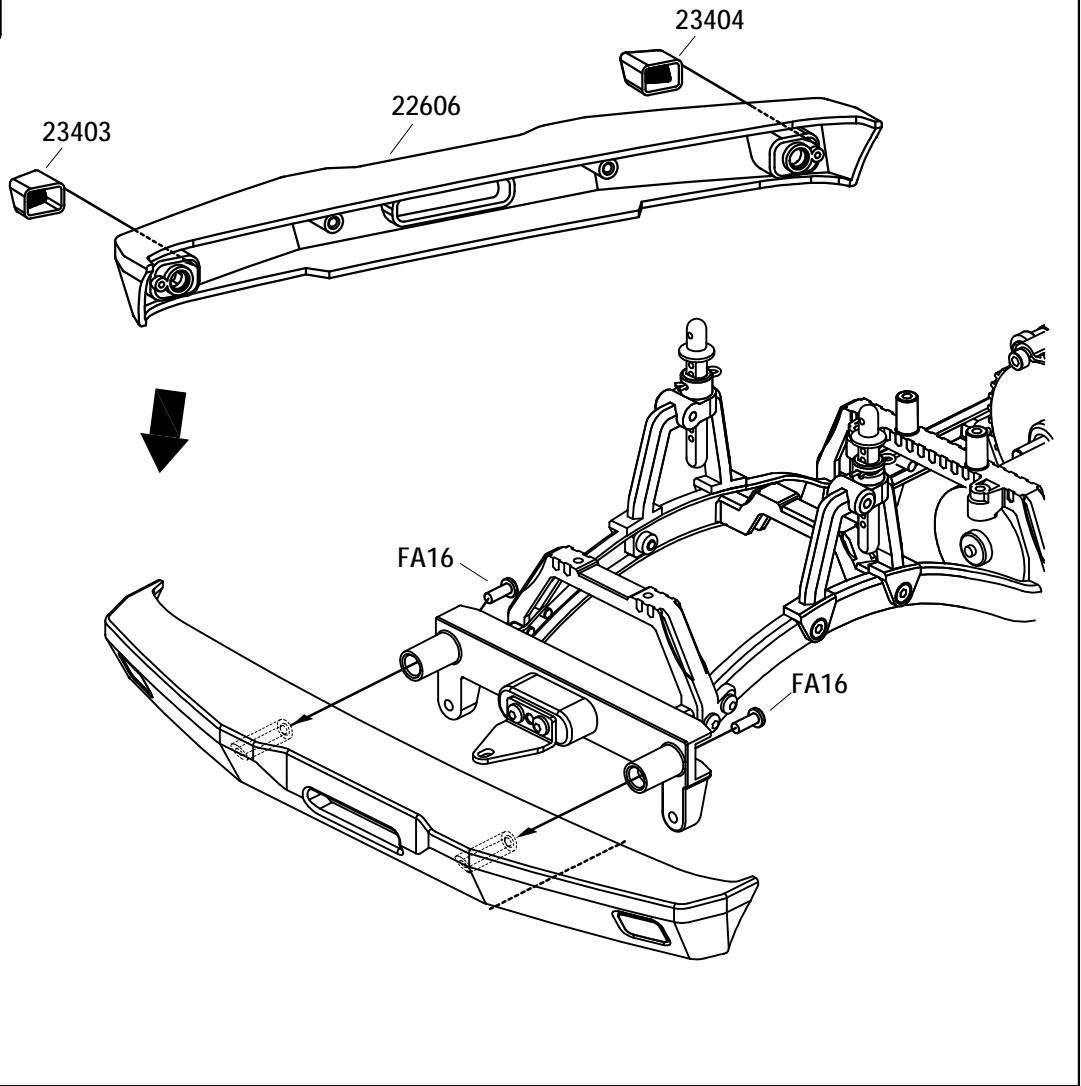

26

FA16  
M3x8 X2

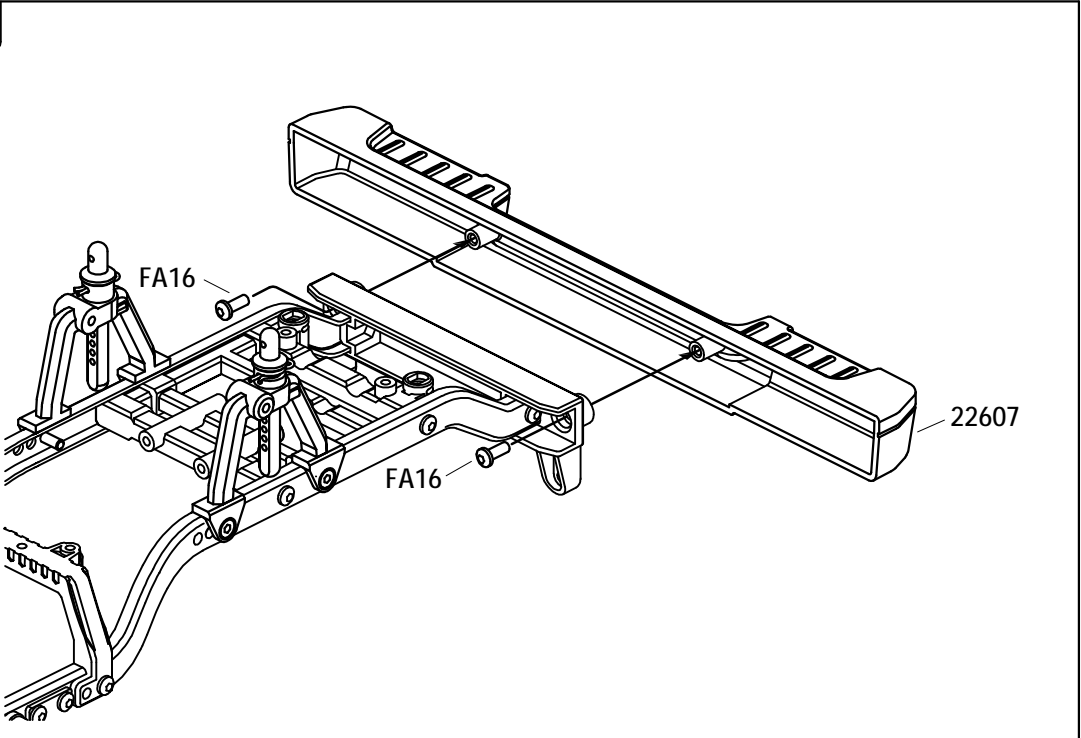

27

FA19 M3x14 X2

FA24 M3x25 X4

FA6 M3x12 X1

FA1 M3 X2

41126 X2  
5

41127 X2  
10

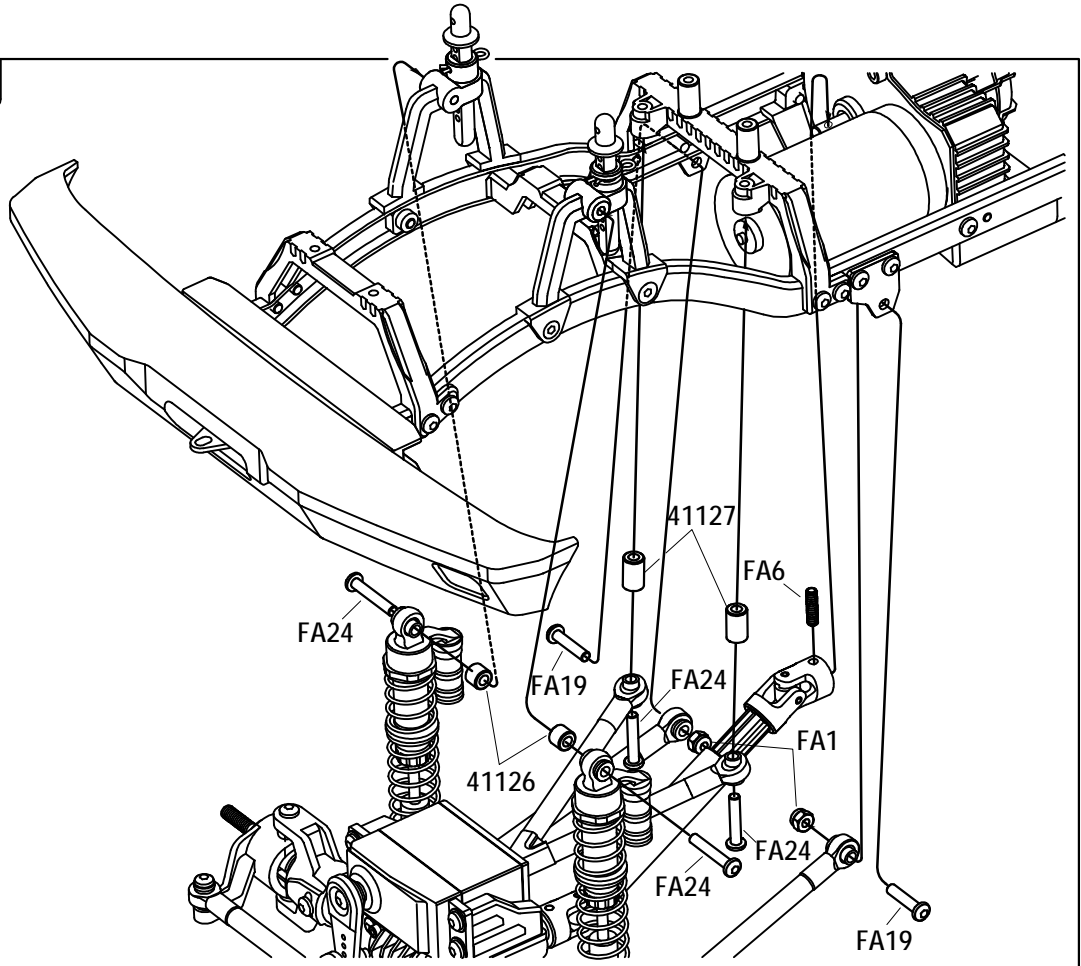

28

41127 X4  
10

FA19 M3x14 X2

FA6 M3x12 X1

FA1 M3 X6

FA24 M3x25 X4

42306 Ø10xØ5x2

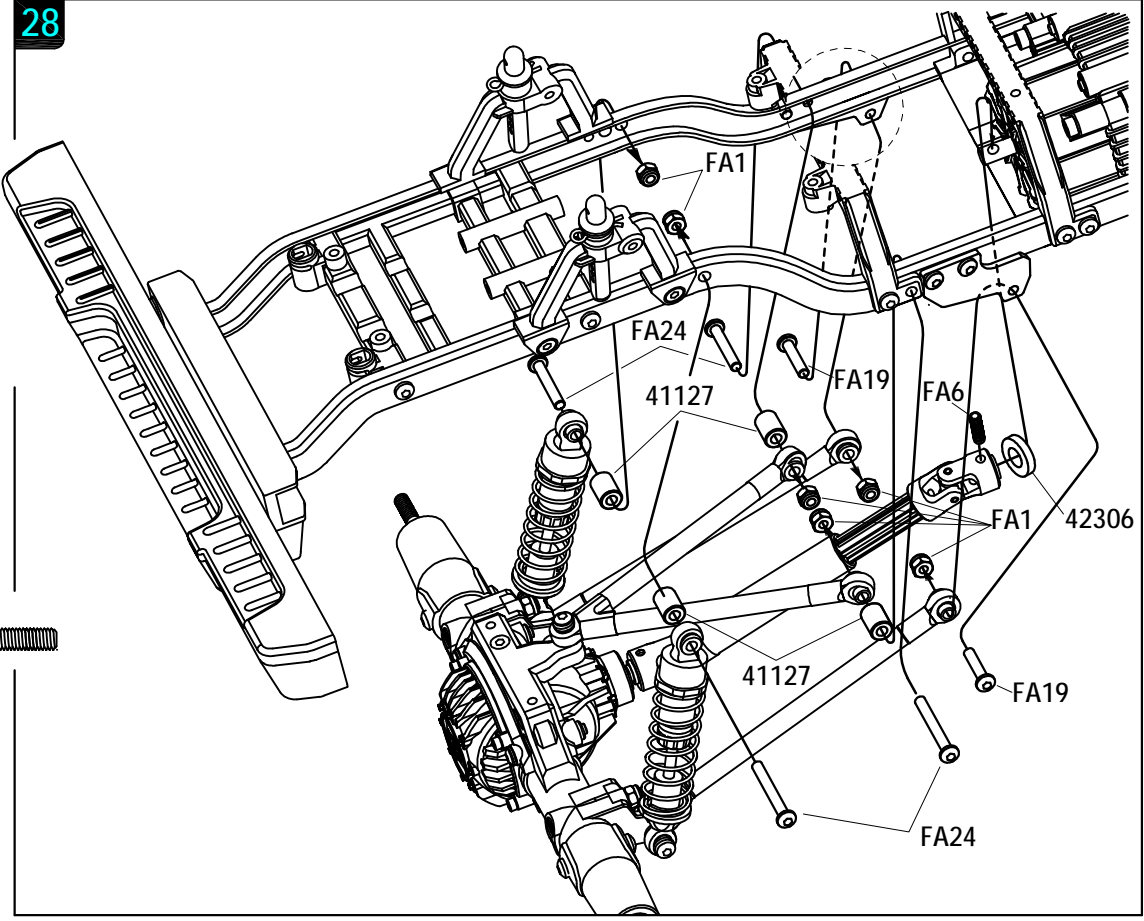

29

FA9



M2x6 X16

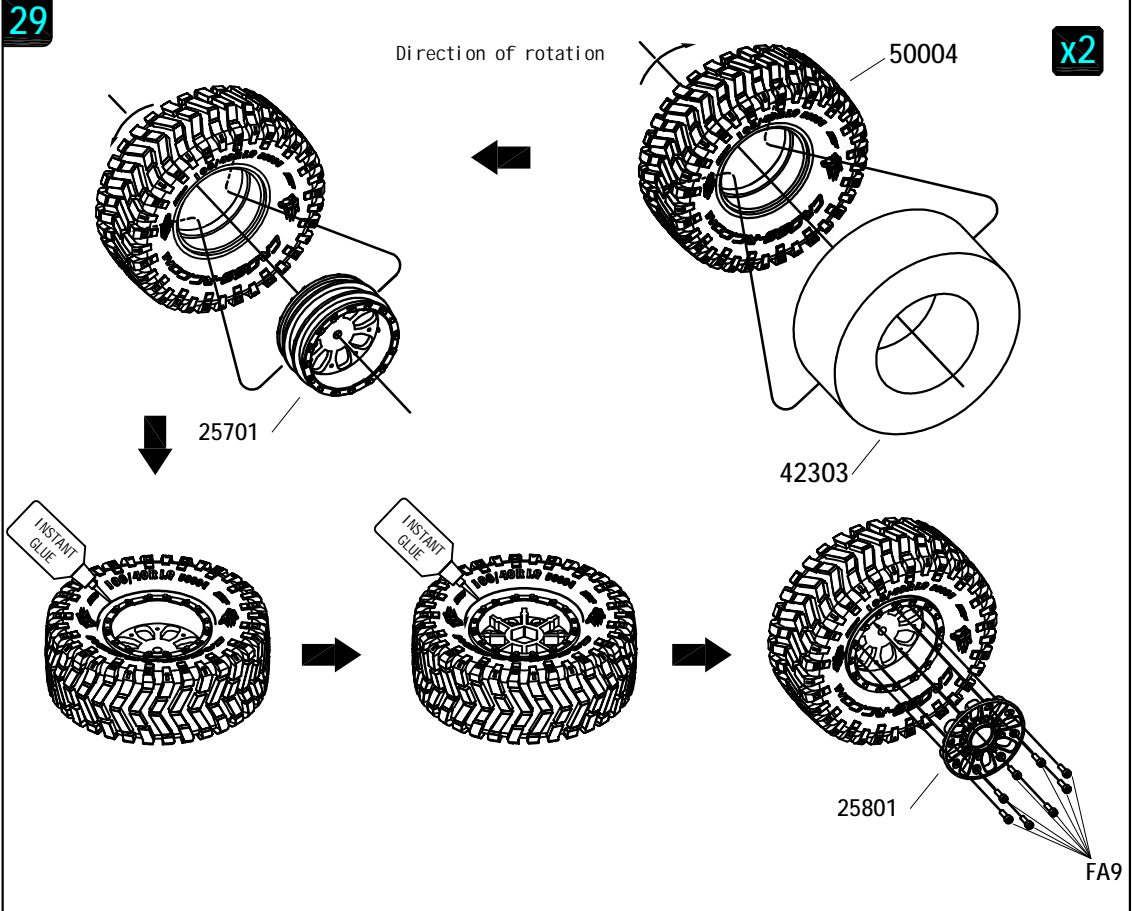

30

FA9



M2x6 X16

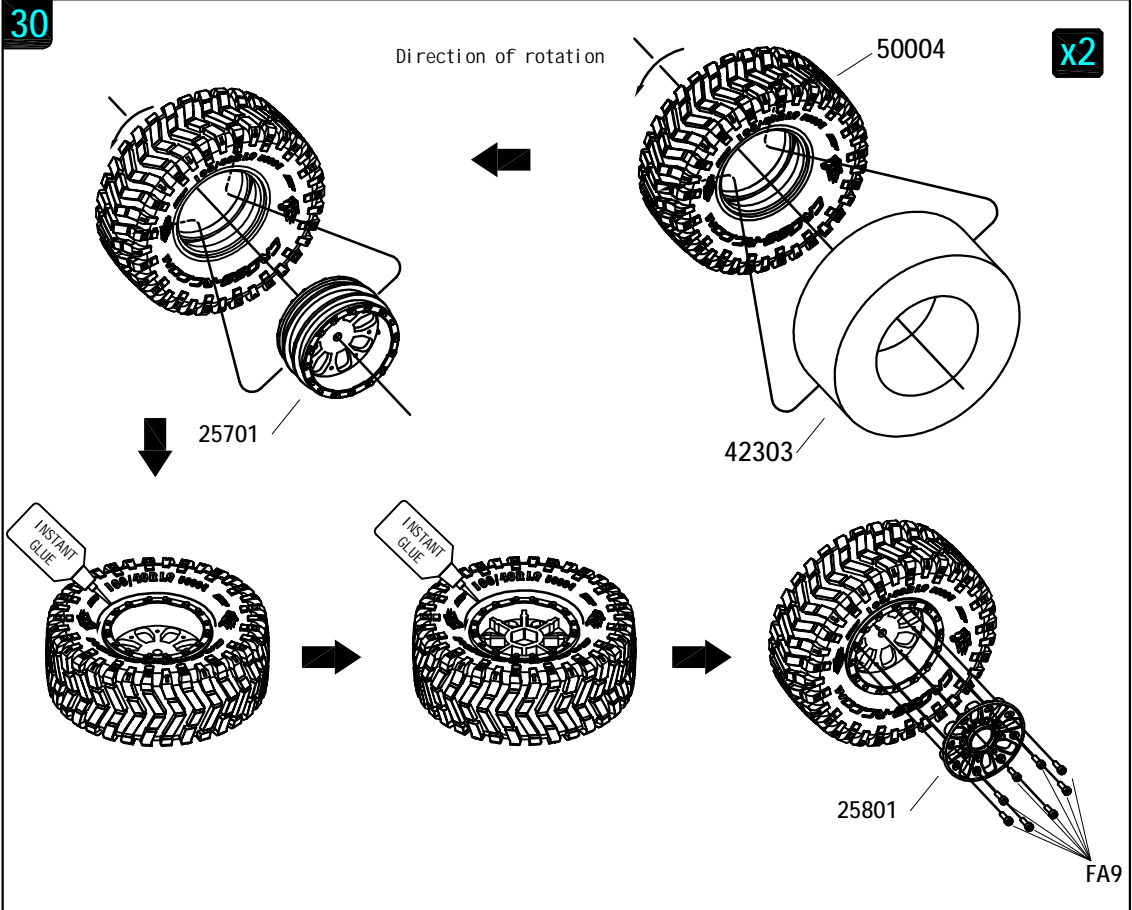





33

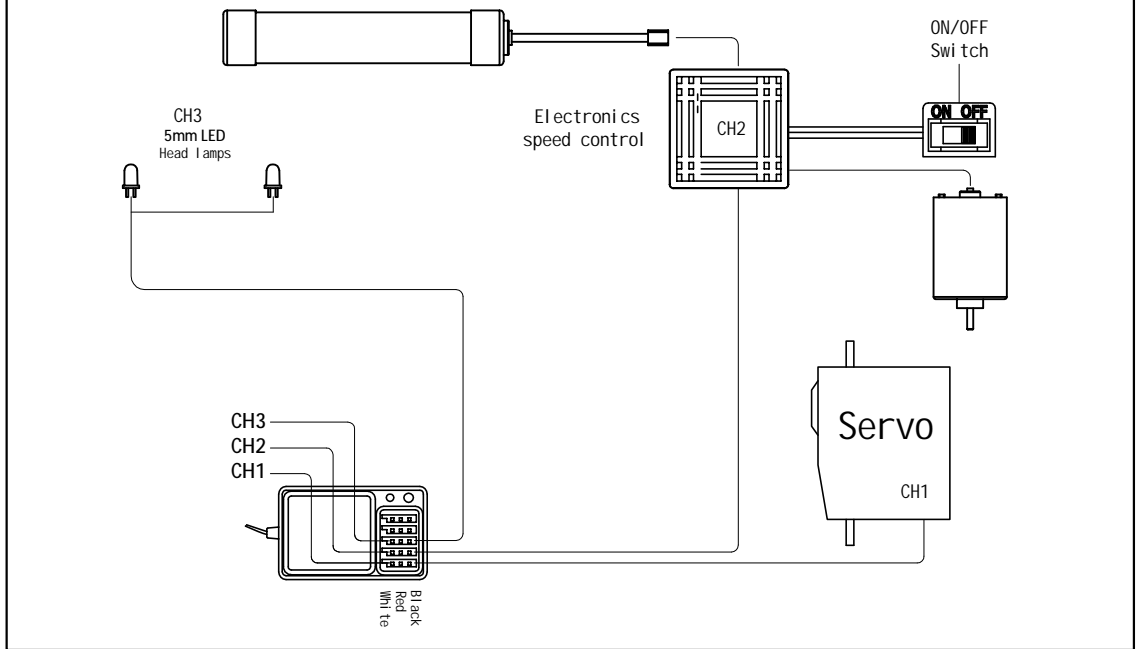

34

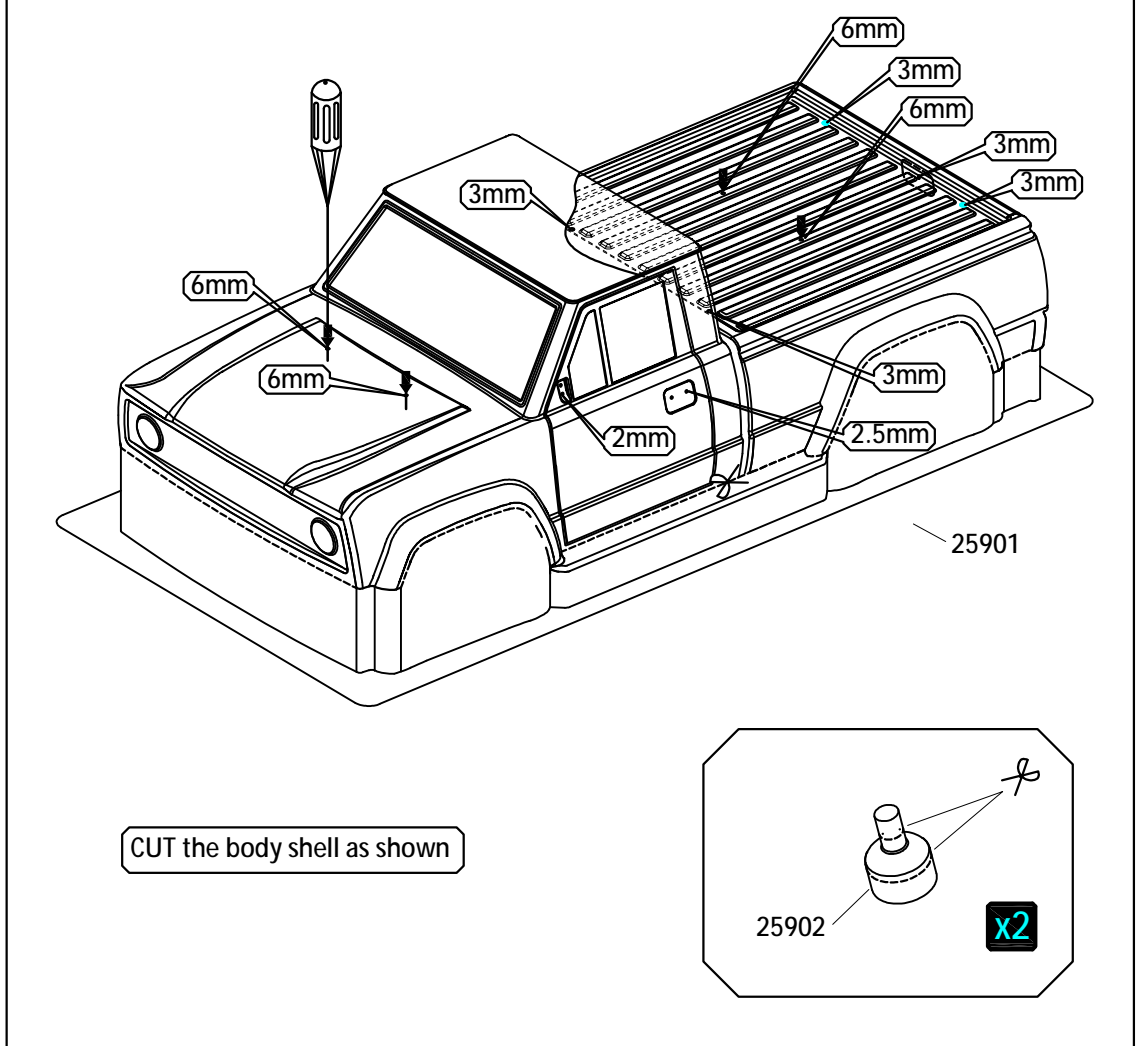

35

Step 1

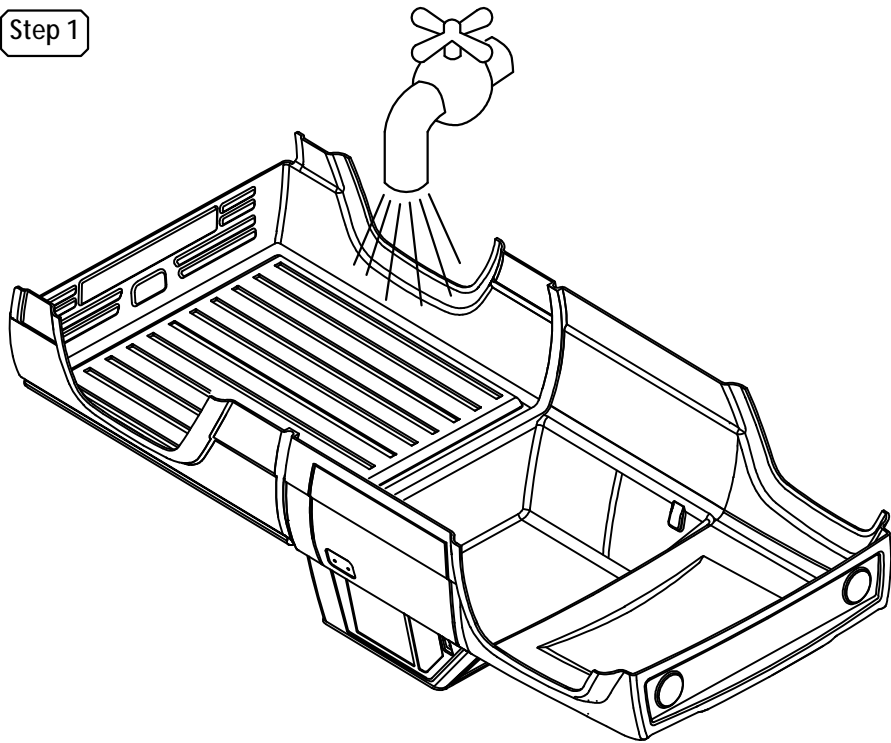

36

Step 2

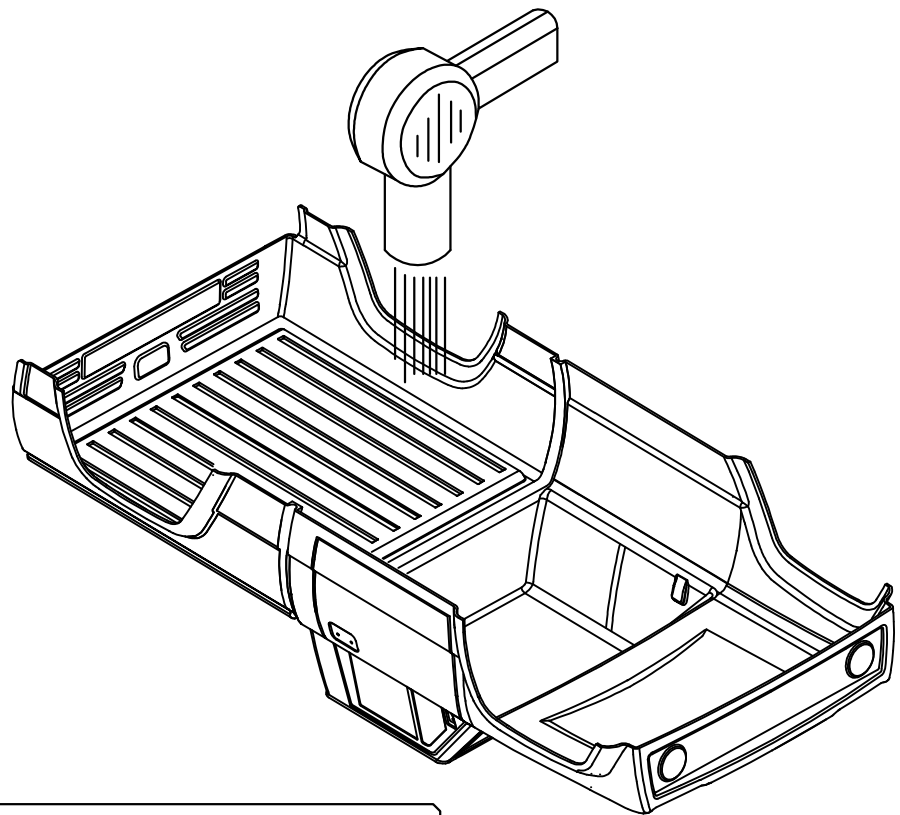

Wash the inside of the body shell with mild detergent, and then rinse and dry thoroughly.

37

Step 3

Mask the windows on the inside with masking tape.

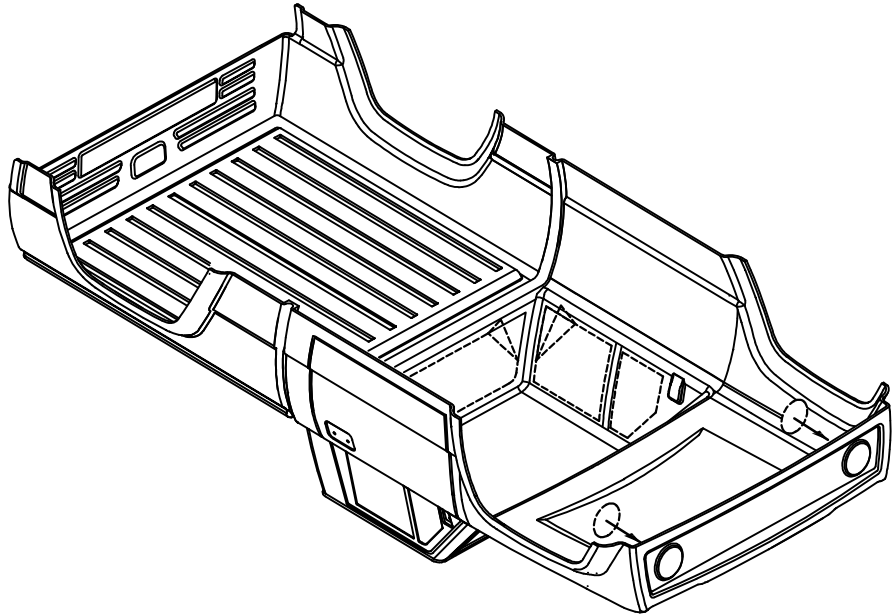

38

Step 4

Paint the body with polycarbonate spray paints.

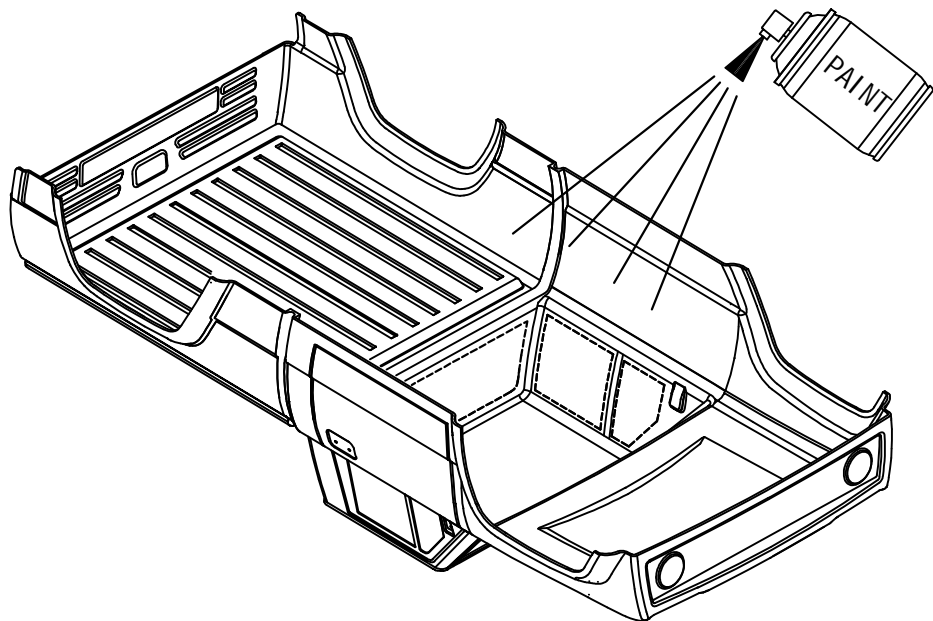

\* When the paint is dry,remove the masking.  
\* When you have finished painting,peel off the external protective films.

25902

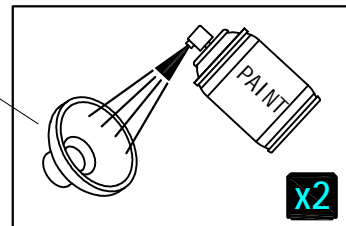

x2

39

FA15   
M3x6 X4

Step 5

42104

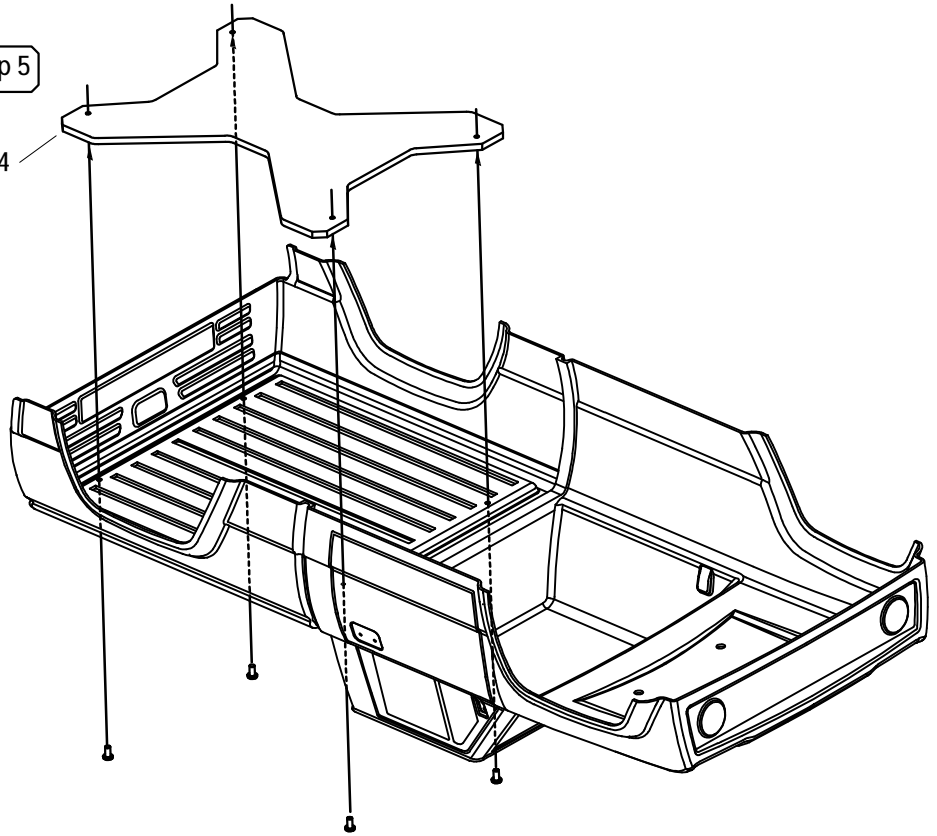

40

FA9   
M2x6 X2

14104

 |  
φ2.2xφ5x0.5 X2

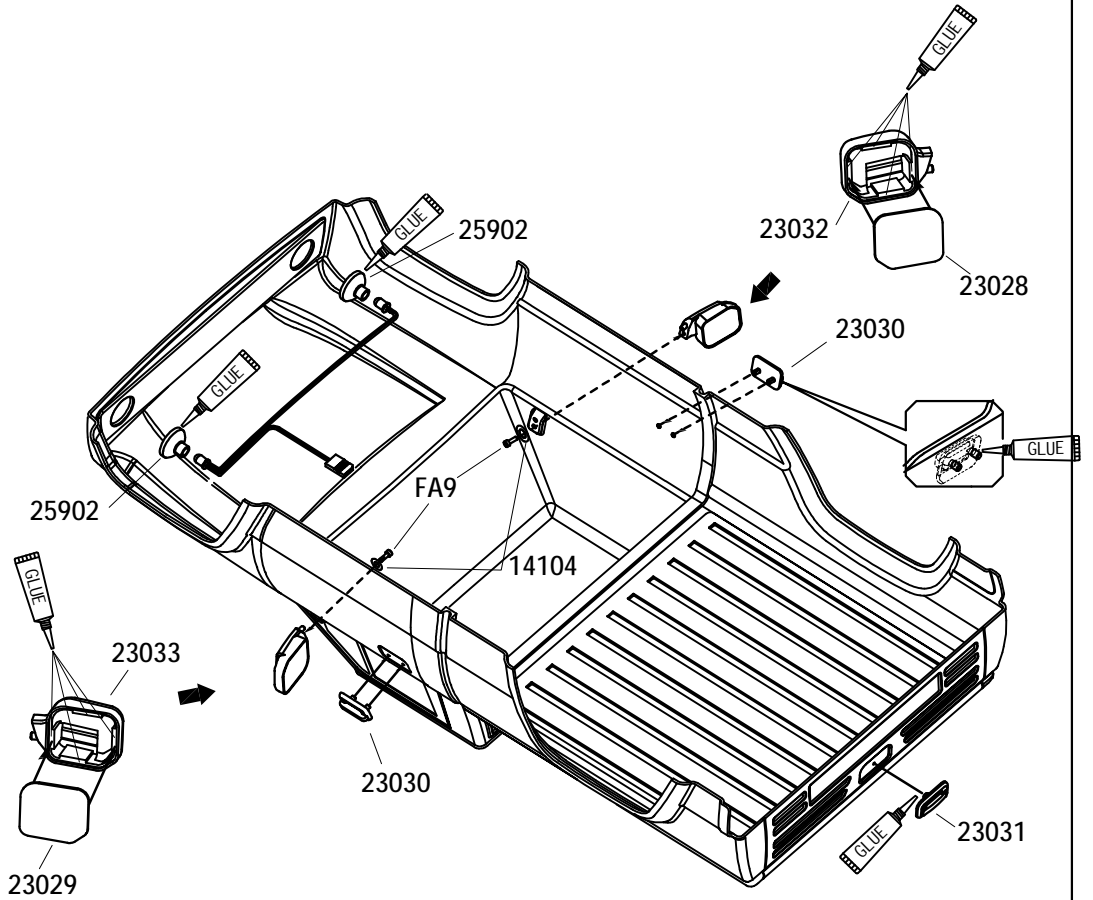

41

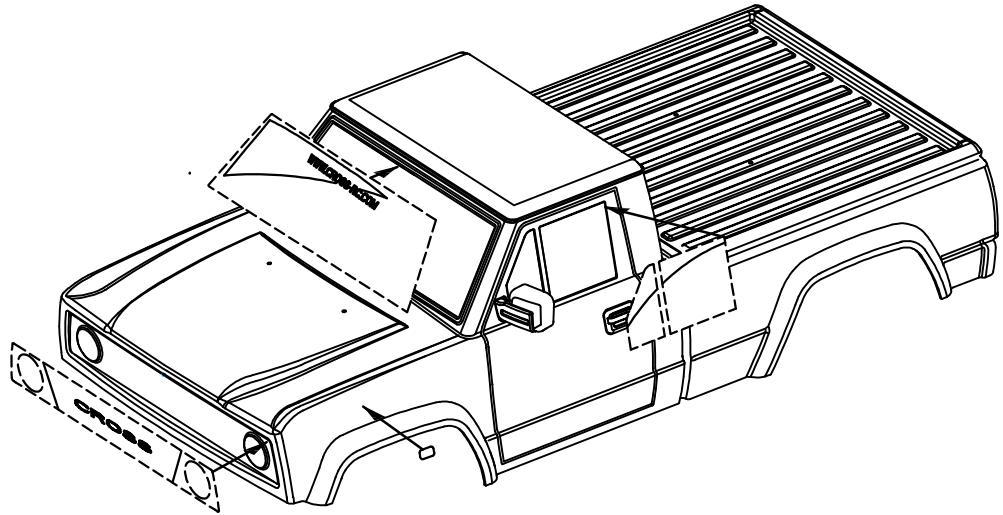

DECAL

42

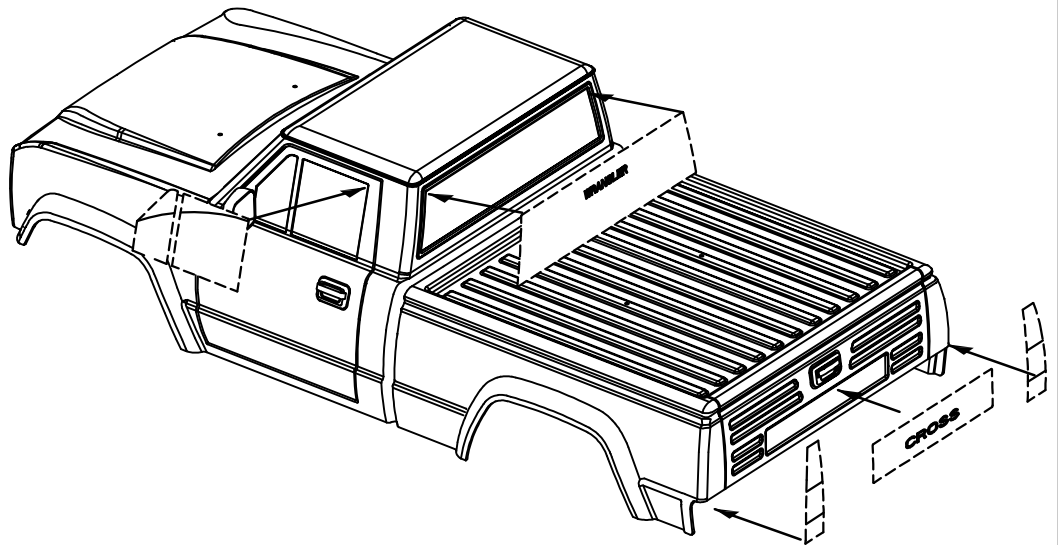

DECAL

  
94015 X4

